

# Runner systems

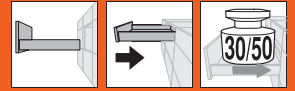

- ▶ TANDEM
- ▶▶ Locking device feature – full extension

## TANDEM plus BLUMOTION – 560H/566H

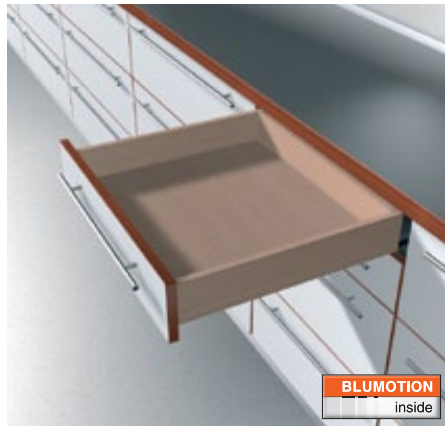

- Concealed TANDEM full extension with integrated **BLUMOTION** for silent and effortless closing action
- TANDEM inside – unsurpassed running action – for the lifetime of the furniture
- Suitable for use with SERVO-DRIVE – the electrical opening support system
- Tool-free height adjustment via a locking device
- Tool-free integrated front tilt adjustment
- Built-in width and depth tolerance compensation

### Space requirement

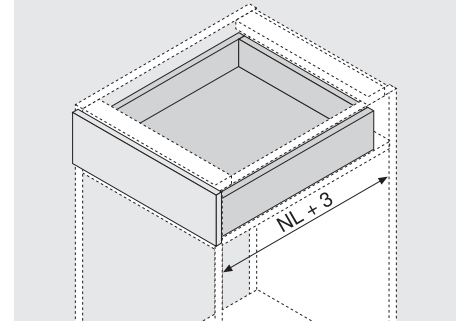

NL Nominal length

### Order information

1	Runners left/right	
<b>Nominal length NL</b>	<b>30 kg</b>	<b>50 kg</b>
250 mm	560H2500B	
270 mm	560H2700B	
300 mm	560H3000B	
320 mm	560H3200B	
350 mm	560H3500B	
380 mm	560H3800B	
400 mm	560H4000B	
420 mm	560H4200B	
450 mm	560H4500B	566H4500B01
480 mm	560H4800B	
500 mm	560H5000B	566H5000B01
520 mm	560H5200B	566H5200B01
550 mm	560H5500B	566H5500B01
580 mm		566H5800B01
600 mm	560H6000B	566H6000B01
650 mm		566H6500B01
700 mm		566H7000B01
750 mm		566H7500B01

3	Locking device left/right		
	<b>Material</b>	<b>Colour</b>	<b>Part no.</b>
	Nylon/zinc	Orange	T51.1700.04
	Order left/right		

a Accessories			
5	POSISTOP		
	<b>Material</b>	<b>Colour</b>	<b>Part no.</b>
	Nylon	RAL 7037 light grey	298.5500
	Depth stop		

4	Front adjuster		
	<b>Material</b>	<b>Colour</b>	<b>Part no.</b>
	Nylon	Natural	295.1000

12	Side stabilisation set for full extension	
	<b>Nominal length NL</b>	<b>Part no.</b>
	Up to 410 mm	ZST.410TV
	Up to 600 mm	ZST.600TV
	Up to 750 mm	ZST.750TV
	For cutting to size, suitable for cabinet width KB 1400 mm	

### Drawer

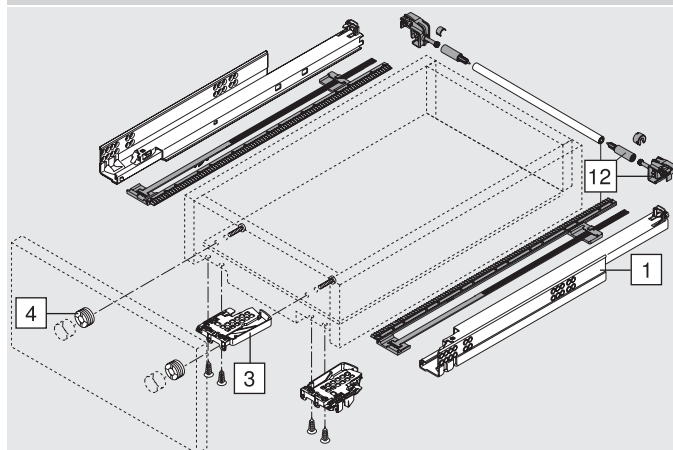

### Inner drawer

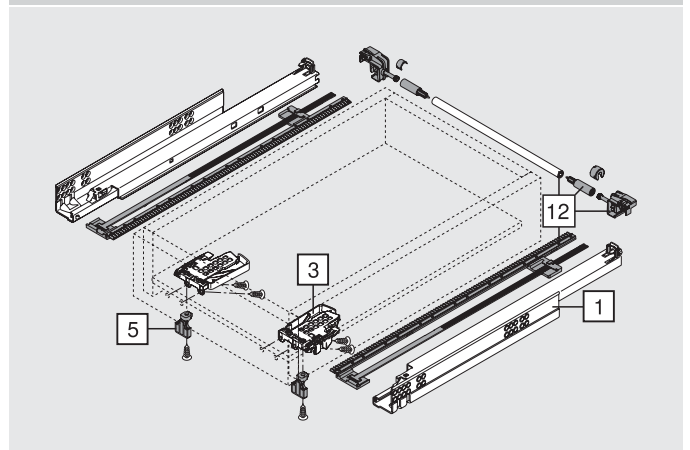

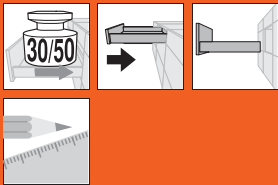

## TANDEM plus BLUMOTION – 560H/566H

### Planning

Space requirement in cabinet	Drawer/inner drawer	Drawer	Inner drawer
* + 3 mm with side stabilisation	SKW Internal drawer width LW Inner cabinet width	SKL Drawer length NL Nominal length * Additional + 12 mm with side stabilisation	ISKL Inner drawer length SKL Drawer length NL Nominal length * Additional + 2 mm with POSISTOP

### Cabinet profile screw positions

Nominal length NL (mm)	Screw positions (mm)
250, 270	96
300, 320	
350, 380	
400, 420	64
450, 480	
500 - 550	128
580, 600	
650 - 750	64, 64, 14, 32, 9, 224, 37

### Drawer assembly

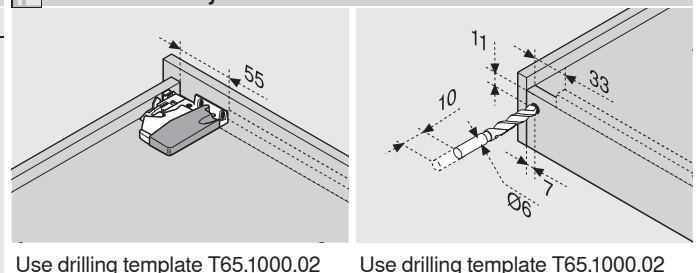

Use drilling template T65.1000.02

Use drilling template T65.1000.02

### Page instructions

Overview – TANDEM	473
Overview – SERVO-DRIVE for MOVENTO/ TANDEM	505
Overview – ORGA-LINE for MOVENTO/ TANDEM	583
Accessories	494
Cabinet profile fixing positions	500
Assembly, removal and adjustment	502
Overview – assembly devices	605
More technical details	684