

Höhe / Height / Altezza / Hauteur - 63 mm

Maßbild / Installation measurement
Misure d'ingombro / Jeu de montage

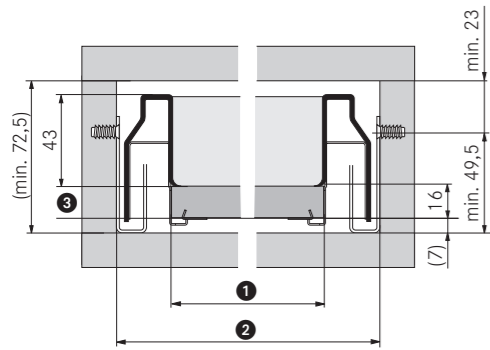

Front ** / Front panel**
Frontale** / Façade**

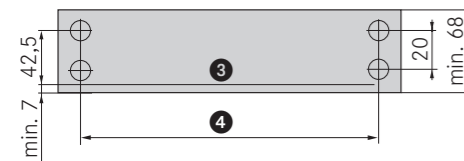

Rückwand / Back panel
Parete posteriore / Retour AR

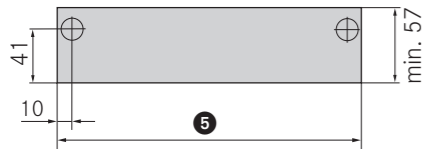

Höhe / Height / Altezza / Hauteur - 90 mm

Maßbild / Installation measurement
Misure d'ingombro / Jeu de montage

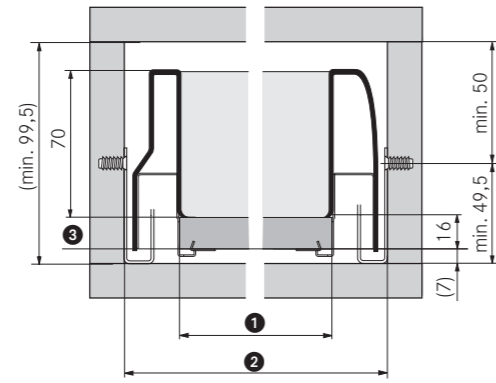

Front** / Front panel**
Frontale** / Façade**

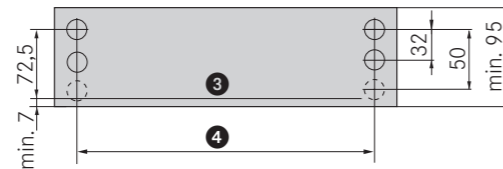

Rückwand / Back panel
Parete posteriore / Retour AR



Höhe / Height / Altezza / Hauteur - 122 mm

Maßbild / Installation measurement
Misure d'ingombro / Jeu de montage

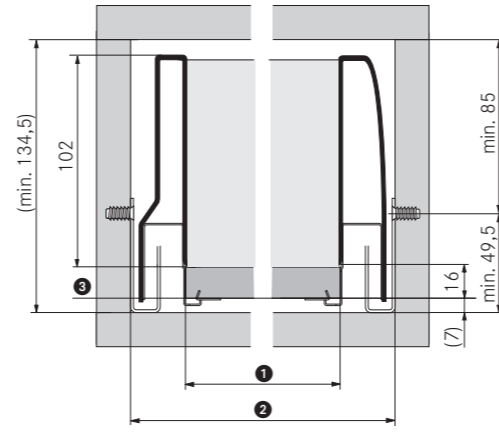

Front** / Front panel**
Frontale** / Façade**

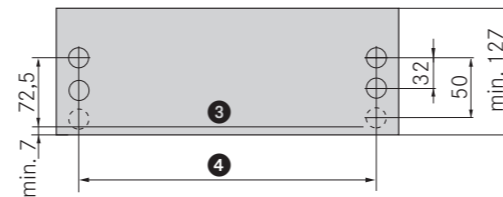

Rückwand / Back panel
Parete posteriore / Retour AR

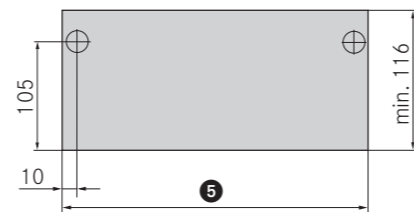

Höhe / Height / Altezza / Hauteur - 90 mm

Nova Pro Crystal

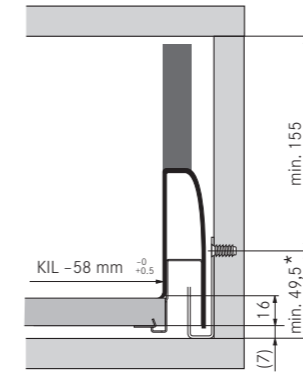

Front** / Front panel**
Frontale** / Façade**

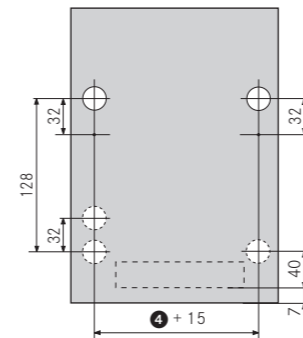

Rückwand / Back panel
Parete posteriore / Retour AR

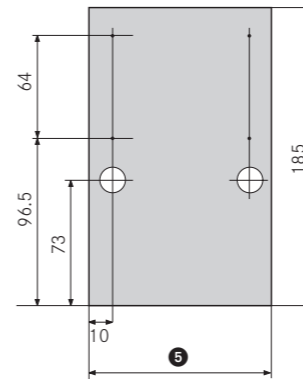

Verstellung, Adjustement, Regolazione, Réglage

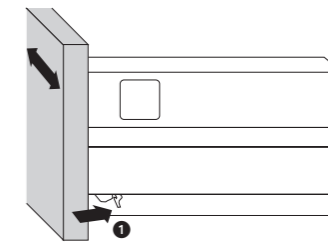

Seitenverstellung: Klemmhebel ① leicht nach hinten drücken, Front leicht anheben und über Riffelung verschieben (Verstellweg ±1,5 mm). Klemmhebel loslassen.

Side adjustment: Press the clamping lever ① lightly to the back and move over the ribbing. Adjustment range is ± 1,5 mm. Release the clamping lever.

Regolazione laterale: Spingere la leva ① leggermente verso dietro, alzare leggermente il frontale e spostarla nella scanalatura, regolazione ±1,5 mm. Lasciare leva.

Latéral: pousser les clips sous-tiroir ① vers l'avant déplacer votre façade latéralement, relâcher les clips. ±1,5 mm.

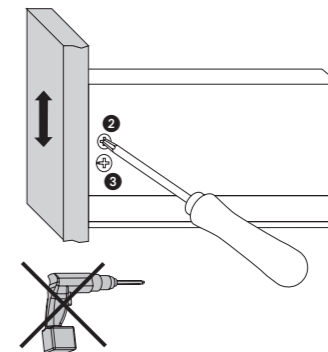

Höhenverstellung: Schraube ② leicht lösen und Front über Exzentrerschraube ③ in die gewünschte Höhenposition bringen. Verstellweg ± 2 mm. Schraube ② festziehen.

Height adjustment: Lightly loosen screw ② and adjust to desired position by means of excenter screw ③. Adjustment range is ± 2 mm. Tighten screw ②.

Regolazione altezza: Allentare leggermente la vite ② regolare la vite eccentrica ③, eportare il frontale nella posizione desiderata. regolazione ± 2 mm. Stringere la vite ②.

Hauteur: desserrer les vis ② intérieures, monter ou descendre la façade à l'aide du vis excentrique ± 2 mm, rebloquer les vis ②.

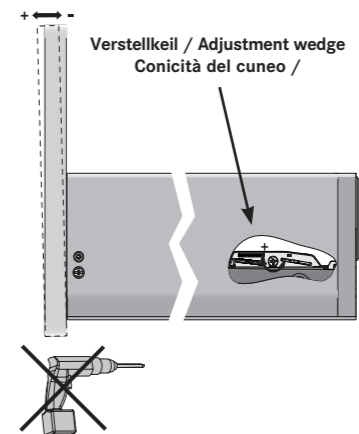

Neu bei Dekorhöhe 122 mm
Neigungsverstellung der Front: Gut zugängliche Neigungsverstellung an der Dekorinnenseite. Neigungsverstellung wird durch Schrägstellung des Schubkastens (± 2mm) erzielt.

New for decor height 122 mm
Tilt adjustment of front: Readily accessible tilt adjustment on the inside of the decor. The tilt adjustment is performed by inclining the drawer (± 2mm).

Nuovo per il cassetto altezza 122 mm
Inclinazione del frontale: Regolazione facile nella parte interna del laterale. Abbiamo la possibilità di ottenere una ottima inclinazione del cassetto (± 2mm).

Nouveau pour decor hauteur 122 mm

DE Deutsch

- ① Bodenbreite = KIL -58 mm +0,5
-0
- ② Korpusinnenlichte (KIL)
- ③ Bodenunterkante
- ④ Bodenbreite +15 mm
- ⑤ Bodenbreite

GB English

- ① Bottom width = ICW -58 mm +0,5
-0
- ② Inside cabinet width (ICW)
- ③ Bottom lower edge
- ④ Bottom width +15 mm
- ⑤ Bottom width

IT Italiano

- ① Larghezza fondo = LIC -58 mm +0,5
-0
- ② Luce interna corpo (LIC)
- ③ Bordo inferiore fondo
- ④ Larghezza fondo +15 mm
- ⑤ Larghezza fondo

FR Français

- ① Largeur du fond = LIM -58 mm +0,5
-0
- ② Largeur int. du meuble (LIM)
- ③ Chant bas du fond
- ④ Largeur du fond +15 mm
- ⑤ Largeur du fond

* Verwendung Crystal für Innenfronten (Front FL) = min. 52,5 mm
* If Nova Pro Crystal is used for internal fronts (front FL) = min. 52,5 mm
* In caso di utilizzo di Nova Pro Crystal per frontali interni (frontale FL) = min. 52,5 mm
* En cas d'utilisation de Nova Pro Crystal pour façades intérieures (façade FL) = au moins 52,5 mm

• Die maximale Fronthöhe mit Abstützung beträgt 780 mm. Möchten Sie eine Front-Sondergröße von über 780 mm mit entsprechender Abstützung montieren, beraten wir Sie gerne. Kontaktieren Sie uns unter info@grass.eu
• The maximum front height with support equals 780 mm. If you want to fit a special front size of more than 780 mm with corresponding support, we will be happy to advise. Contact us at info@grass.eu
• L'altezza massima del frontale con sostegno è pari a 780 mm. Siamo a disposizione nel caso in cui si desideri montare un frontale avente dimensioni speciali superiori a 780 mm, con relativo sostegno. Ci contatti all'indirizzo info@grass.eu
• La hauteur de façade maximale avec appui est de 780 mm. Vous souhaitez monter une façade d'une hauteur spéciale de plus de 780 mm avec appui adéquat ? Nous nous ferons un plaisir de vous conseiller. Veuillez nous contacter à l'adresse info@grass.eu

Korpusschienen / Cabinet member / Controguide / Perçages coulisses fixes

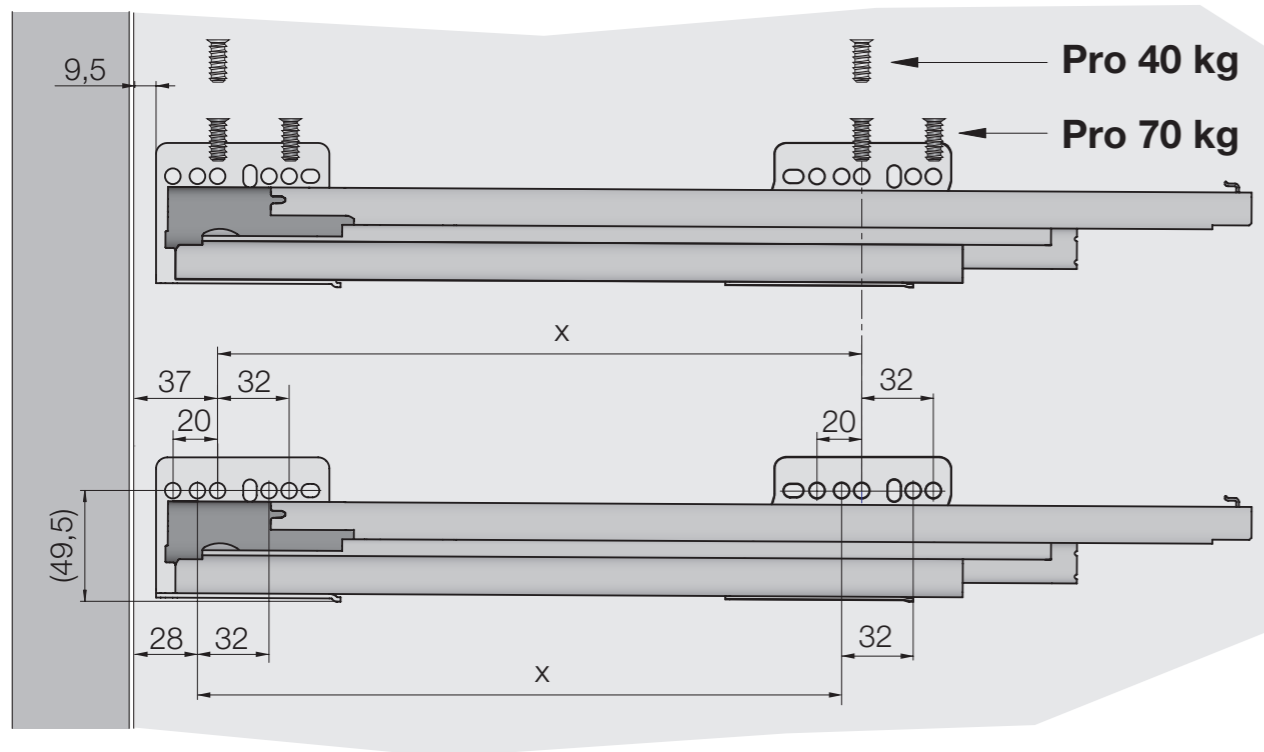

Führungslänge / Drawer slide length / Lunghezza guida / Longueur de guidage

	270 mm	300 - 400 mm	450 - 600 mm	650 mm
X	160 mm	224 mm	288 mm	352 mm

Korpusschienenbefestigung:	Euroschraube Ø 6 x min. 13 mm	Fronthakenbefestigung:	Dübel Ø 10 x 11 mm, alternativ Spanplattenschraube 3,5 x min. 11 mm
Cabinet member mounting:	Euroscrew dia. 6 x min. 13 mm	Front hook fastening:	Dowel dia. 10 x 11 mm, or wood screw 3.5 x min. 11 mm
Controguide:	Euro Ø 6 x min. 13 mm	Fissaggio del gancio frontale:	caviglia Ø 10 x 11 mm, in alternativa vite 3,5 x min. 11 mm
Perçages coulisses fixes:	Euro-vis Ø 6 x min. 13 mm	Fixation attache-façade:	Cheville Ø 10 x 11 mm, ou vis SPAX 3,5 x min. 11 mm

Unter Verwendung einer Spanplattenqualität - bezogen auf den Schraubenausziehewiderstand nach DIN EN 320 (>1.000 N) - empfehlen wir die Befestigung mit Standard Euro Schraube Ø 6 x 13 mm nach obigem Schraubbild. Befestigungsarten, die von der Vorgabe abweichen, sind durch den Möbelhersteller zu prüfen.

When using chipboard quality - with regard to the screw pull-out force to DIN EN 320 (>1000 N) - we recommend fastening with a standard Euro screw dia. 6 x 13 mm as shown in the above diagram. Fastening methods which differ from the specification are to be tested by the furniture manufacturer.

Nel caso in cui la qualità del pannello di truciolato impiegato si riferisca a resistenza all'estrazione assiale della vite indicata nella DIN EN 320 (>1.000 N), consigliamo di effettuare il fissaggio con vite euro standard Ø 6 x 13 mm, come da schema in alto. Eventuali modalità di fissaggio differenti da quanto prescritto dovranno essere verificate dal fabbricante del mobile.

En cas d'utilisation d'une qualité de panneau aggloméré présentant une résistance aux forces d'arrachement des vis selon DIN 320 (> 1 000 N) - nous recommandons la fixation par vis Euro standard de Ø 6 x 13 mm selon le schéma figurant ci-avant. Tout type de fixation s'écartant du mode décrit doit être contrôlé par le fabricant de meubles.

Zusammenstellung

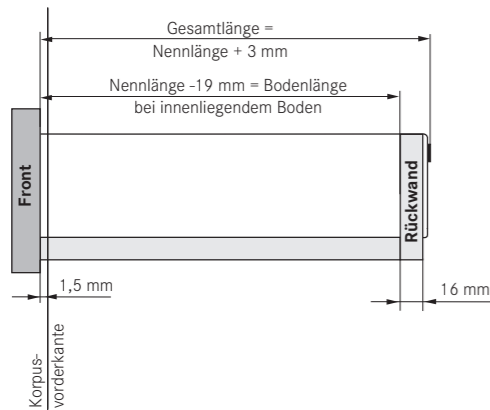

Assembly

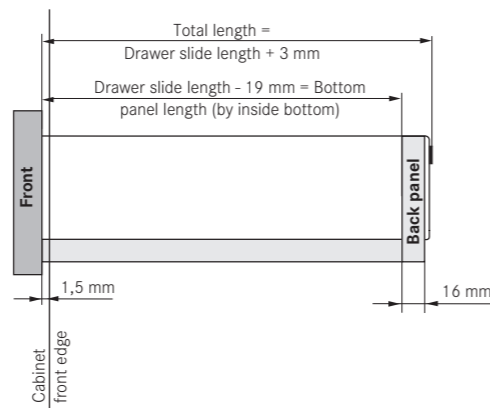

Assemblaggio

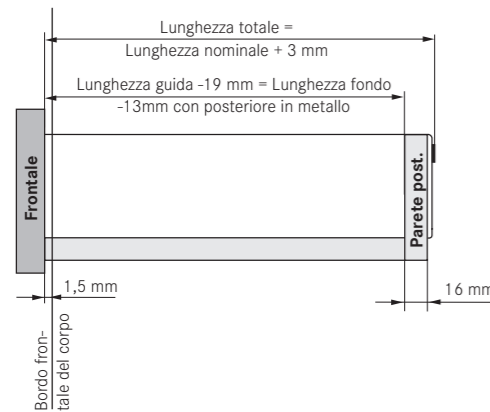

Assemblage

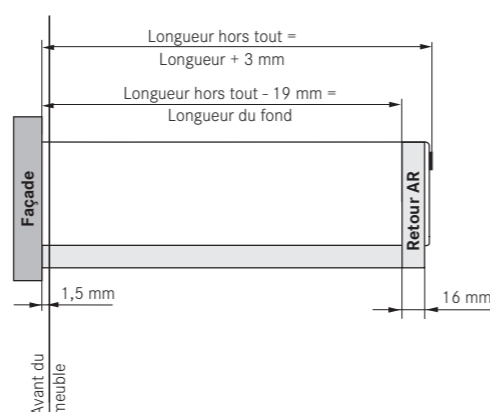

Schubkasten-Montage / Drawer assembly / Montaggio di cassetto / Montage de tiroir

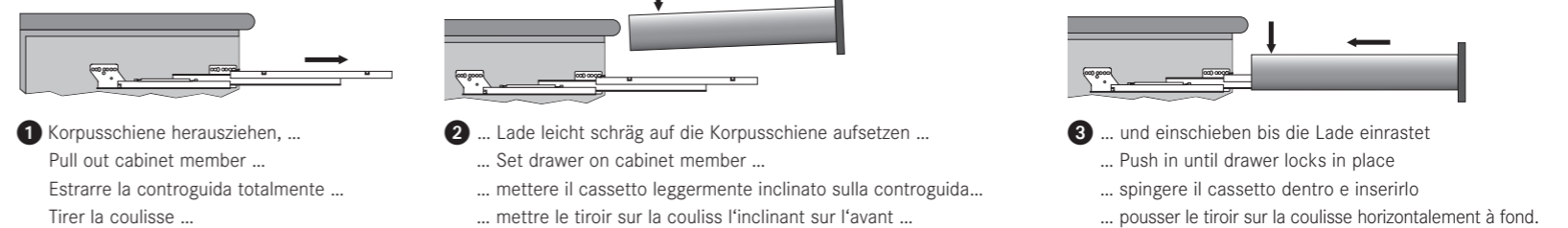

Schubkasten-Demontage / Drawer removal / Smontaggio di cassetto / Demontage de tiroir

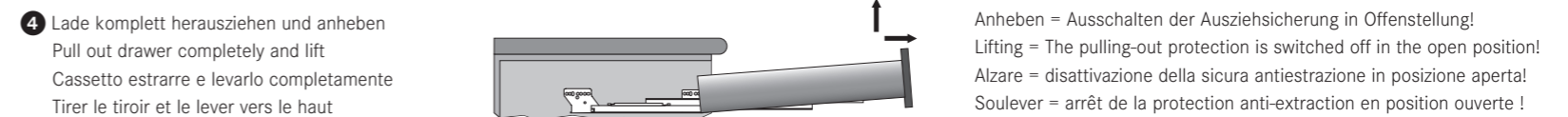

Montage auf der Grass Zargenlehre / Installation by use of Grass Assembly Jig Montaggio con la dima Grass / Montage des profils Grass

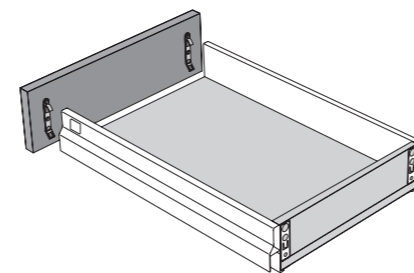

Rückwand ① und Boden ② mit den Zargen ③ verkrallen, bzw. verdübeln. Auf Zarge ③ Körnerlehre aufstecken, Front ④ andrücken und Fronthaken an den gekörnten Positionen befestigen.

Press together back panel ① and bottom ②, fix bottom grips and back panel dowels. Corner templates are placed on the Zargen slide. Press the front ④ and fasten the front hooks to the cornered position.

Unire la parte posteriore ① e il fondo ② con i telai ③ tramite la dima Grass. Mettere la dima per centrare i fori sul telaio ③ ed appoggiare il frontale ④ e fissare i ganci frontali sulle posizioni dei fori.

Le retour AR ①, le fond ② et les profils ③ sont assemblés par des griffes à enfoncer, à frapper (chevilles AR) ou par vissage. La façade ④ avec ses 2 pattes de fixation vient se clipser sur les profils ③.