

Full extension undermount slides installation

16mm /19mm Drawer installation dimensions(with locking device)

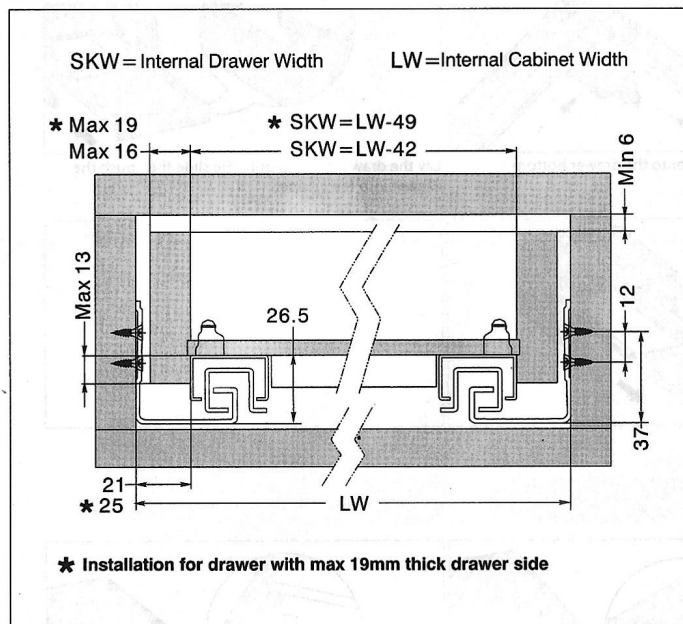

16mm /19mm Drawer installation dimensions(with peg)

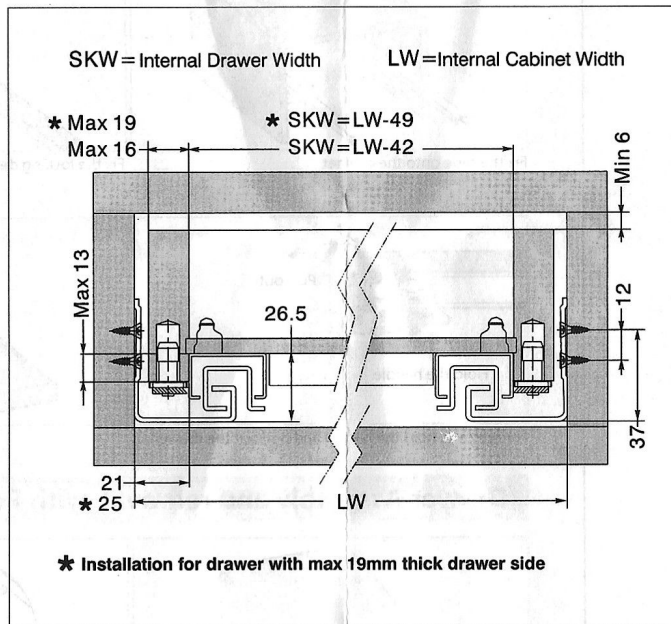

Standard drawer installation dimensions

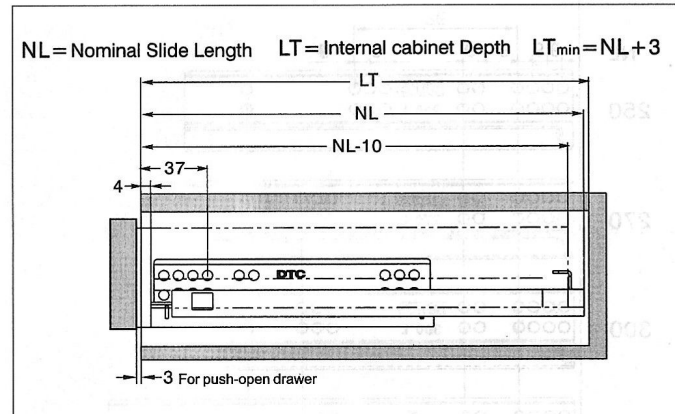

Inner drawer installation dimensions

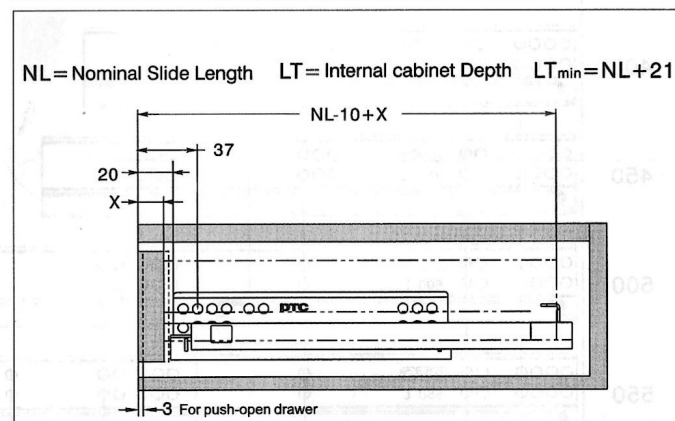

Drawer preparation

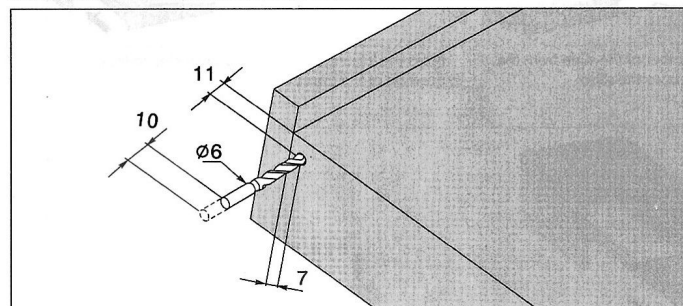

Drawer preparation

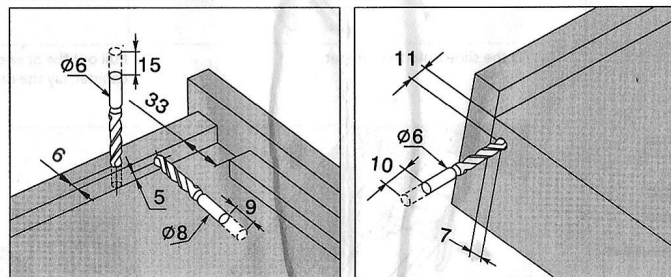

Locking device installation

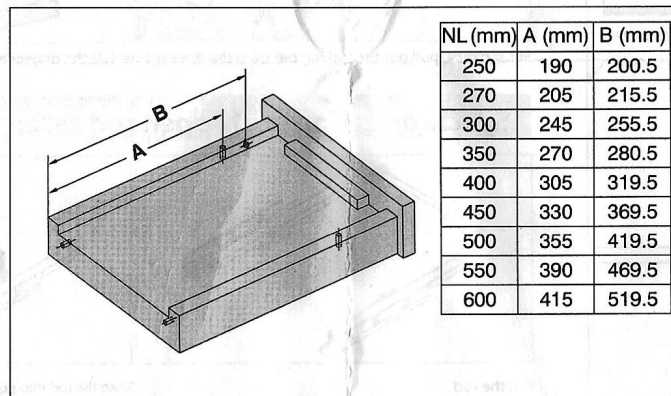
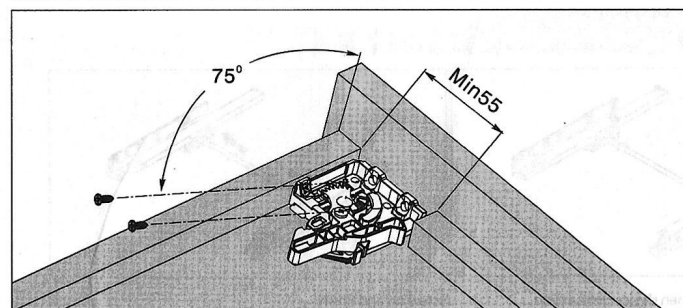

Cutting dimension of rod for Push-open synchronization (mm)

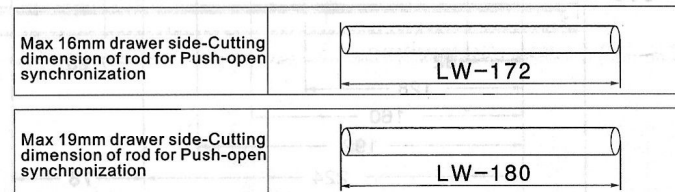

DTC
Global Quality Benchmark

Website: www.dtcetc.com

Screw Positions of the Slides

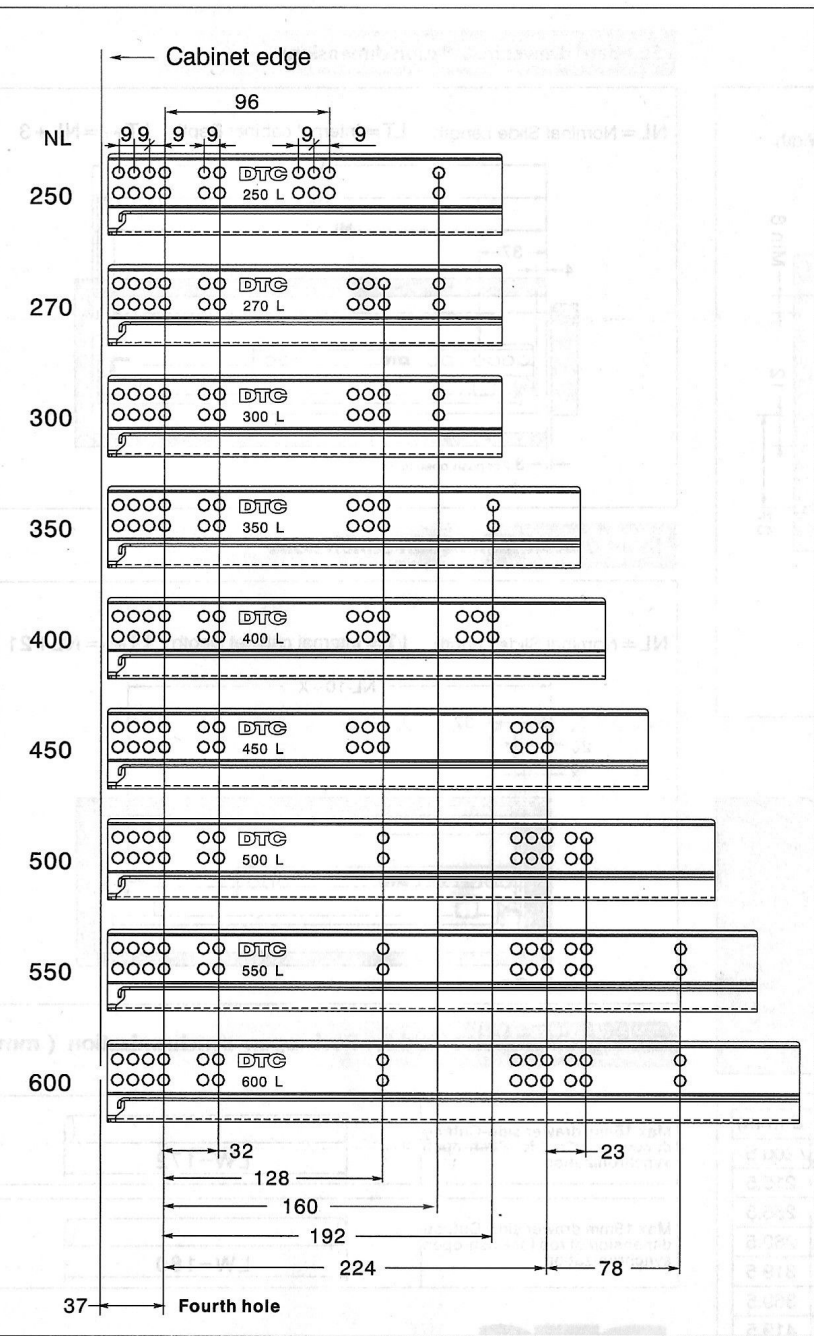

Fixing hole position for inner drawer

37 Second hole

Drawer Assembly and Removal with Locking Device

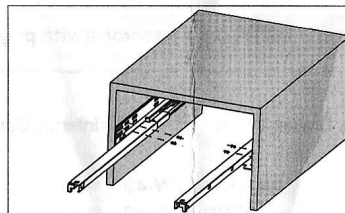

Fix the slide onto the cabinet

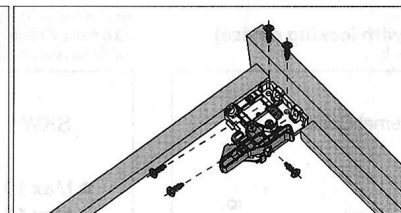

Fix the locking device onto the drawer bottom

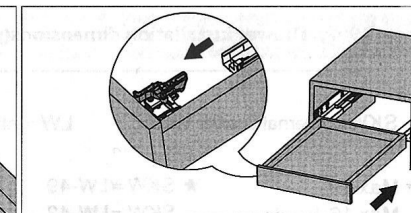

Lay the drawer bottom onto the slide then push the drawer into the cabinet

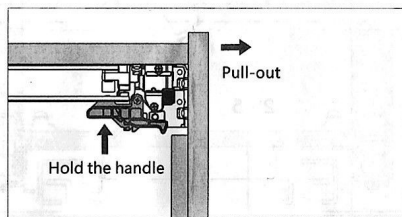

For removal, hold the handle and pull out the drawer

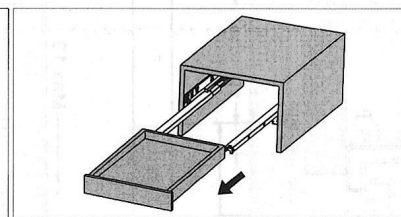

Drawer Assembly and removal with Peg

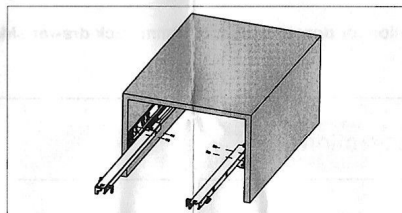

Fix the slide onto the cabinet.

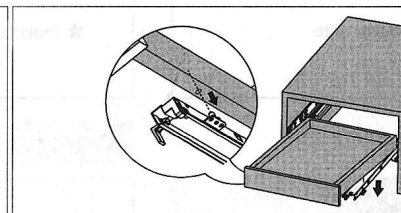

Pull out the drawer member of the slide from the cabinet, lay the drawer onto the slide

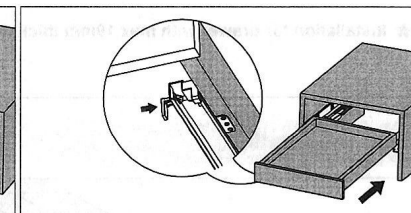

Press the locking pin into the drawer side to lock the position of the drawer

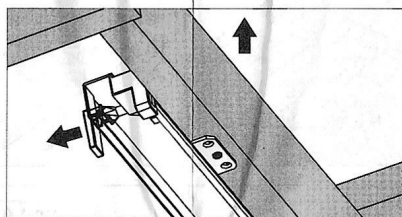

For removal, pull out the locking pin from the drawer side. Lift the drawer and pull it out from the cabinet

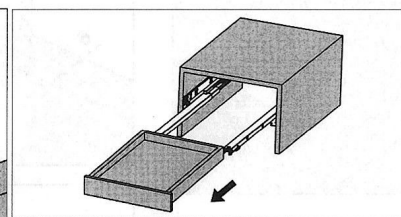

Synchronization push-open rod assembly

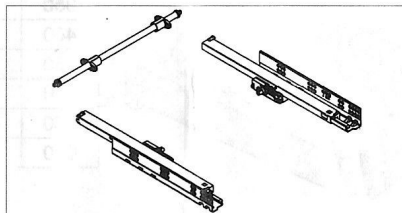

Cut the rod

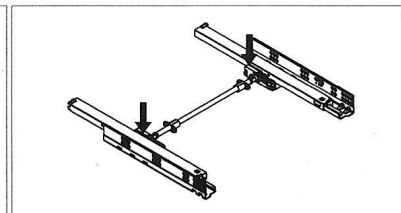

Snap the rod into push-open device on the slide

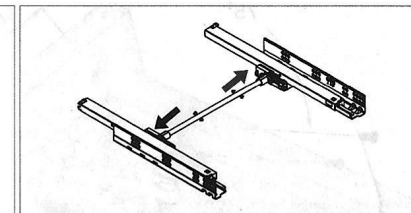

Screw on and finish