



# WASTEBIN 600mm 70 Lt

REV. 00.2017  
FOIST00085

Prodotto ed assemblato in Italia / Made and assembled in Italy / Fabriqué et assemblé en Italie / Hecho y montado en Italia

## CARATTERISTICHE • FEATURES • CARACTÉRISTIQUES • CARACTERÍSTICAS

Pattumiera ad estrazione totale da 600 mm Lt.70  
Full extension wastebin 600 mm Lt.70  
Poubelle sortie totale 600 mm Lt.70  
Cubo de basura a extracción total 600 mm Lt.70

## MINUTERIA INTERNA • FITTINGS • FERRURE • PEQUEÑA CUBIERTA

**n°12 3,9x13** Vite autofilettante TC a croce / Self tapping screw TC  
Vis autotaraudeuse TC / Tornillo autorroscante TC  
**n°8 4x16** Vite autofilettante TSP a croce / Self tapping screw TSP  
Vis autotaraudeuse TSP / Tornillo autorroscante TSP  
**n°4 M4x5** Vite cilindrica / Cylindrical screw / Vis cylindrique / Tornillo cilíndrico

## COMPONENTI • PARTS • COMPOSANTS • COMPONENTES

- A. n°1** Box metallico / Metal box / Boîte en métal / Caja de metal
- B. n°1** Coperchio / Lid / Couvercle / Tapa
- C. n°1** Kit guide Sige / Kit Sige slides / Kit glissières Sige / Kit de guías Sige
- D. n°1** Coppia carter guide / Kit slide cover  
Kit carter pour la glissière / Kit carter para las guías
- E. n°2** Lamiera reggi coperchio / Metal plate lid holder  
Support pour couvercle tôle / Placa de metal para sostener la tapa
- G. n°1** Coppia attacco antina / Kit door fixing brackets  
Kit pattes de fixation sur la porte / Kit soportes de fijación de la puerta
- I. n°2** Cover attacco antina / Door fixing cover  
Carter pour la patte de fixation / Cover para los soportes de fijación
- L. n°4** Tappo / Stopper / Bouchon / Tapòn
- M. n°2** Secchio pattumiera 35 Lt. / Wastebin Lt.35 / Poubelle Lt.35 / Cubo de basura Lt.35

UTENSILERIA • TOOLS  
OUTILS • INSTRUMENTOS

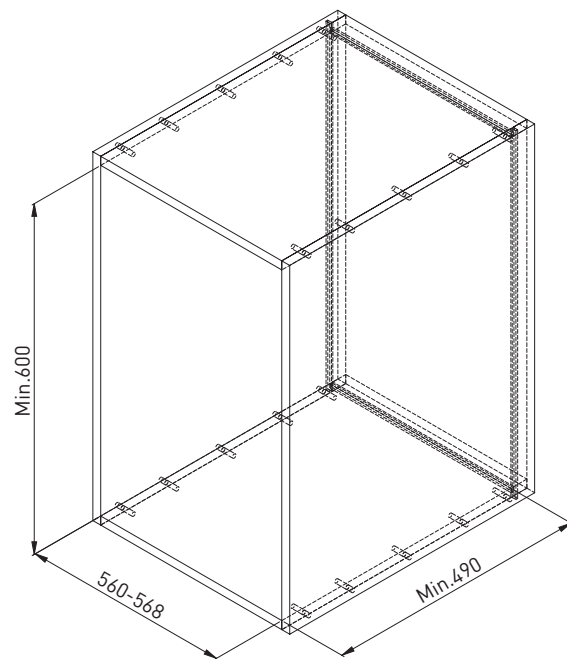

### SIGE SLIDES 30 KG LOAD

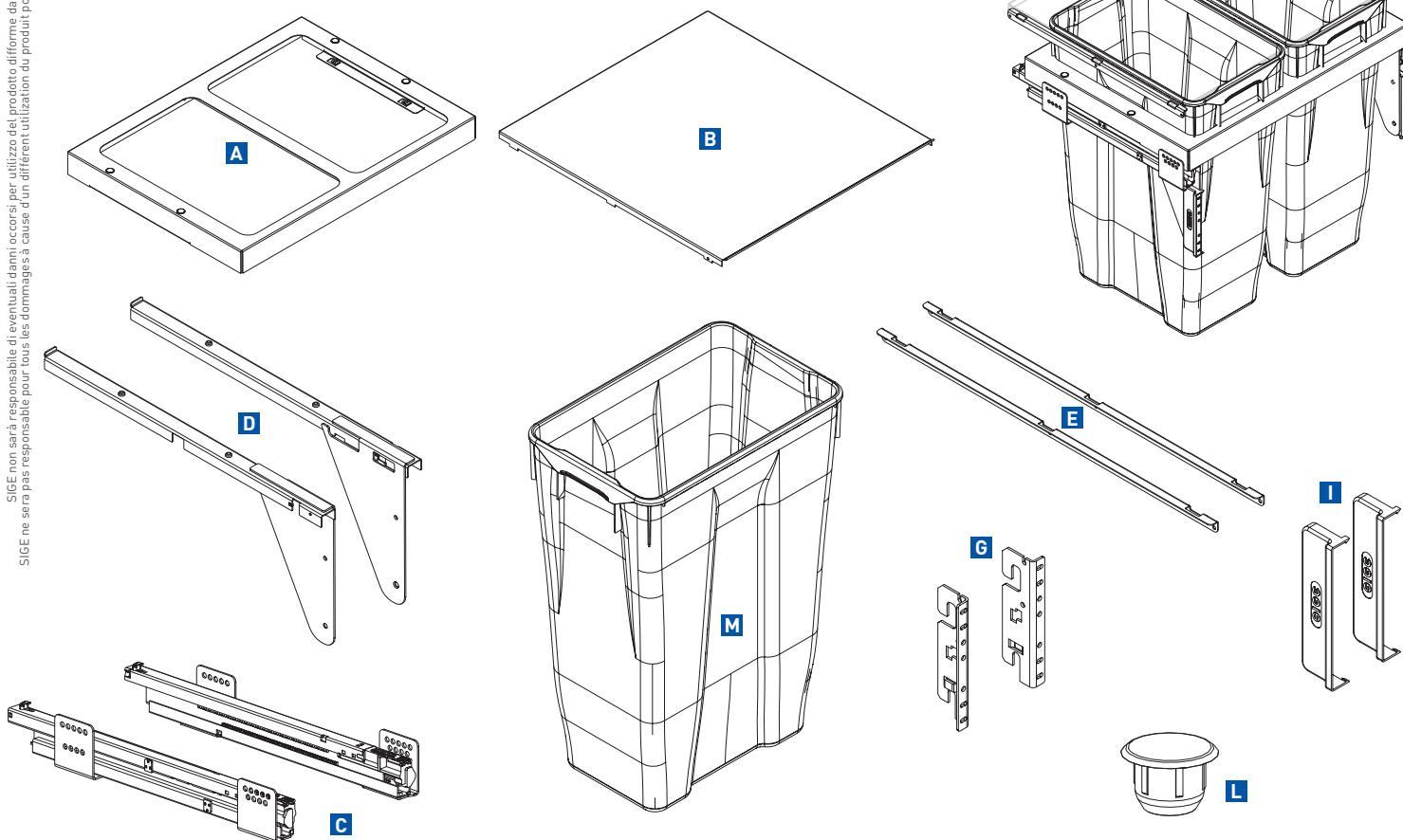



1

Fissare le guide C e le lamiera reggi coperchio E rispettando le quote.

Fix the Sige slides C and the metal plate lid holder E according to the dimensions.

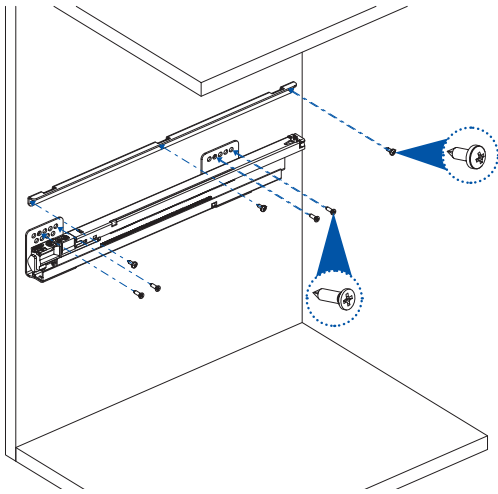

Fixez le kit glissières Sige C et le support pour couvercle tôle E en respectant les dimensions.

Fijar el kit de guías Sige C y la placa de metal para sostener la tapa E respetando las medidas.

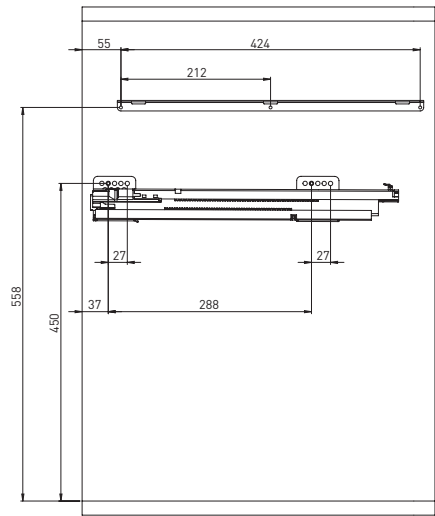

2

Inserire la coppia carter guide D nelle guide C.  
Put the kit slide carter D into the Sige slides C.

Insérez le kit carter pour la glissière D dans les glissières C.  
Colocar el kit carter para las guías D sobre las guías Sige C.

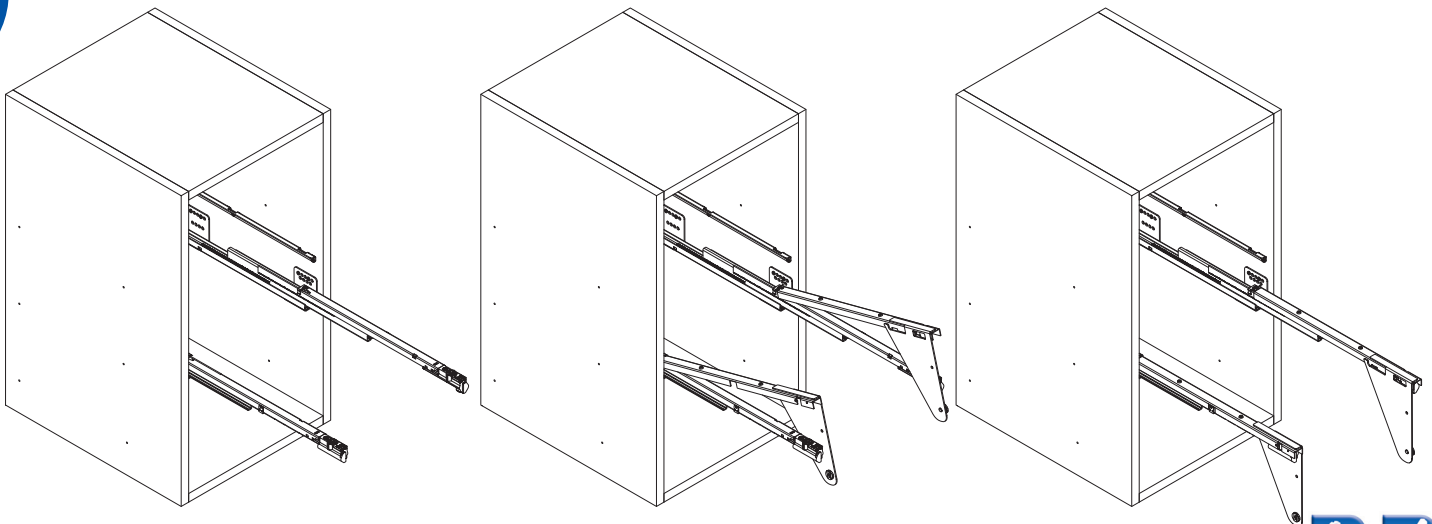

N°4 M4x5



3

Avvitare il box metallico A nei carter guide D mediante le apposite viti.

Screw the metal box A into the kit slide carter D by using the specific provided screws.

Vissez la boîte en métal A dans le kit carter pour la glissière D avec les spécifiques vis fournies.

Atornillar la caja de metal A en el kit carter para las guías D con los tornillos provistos.

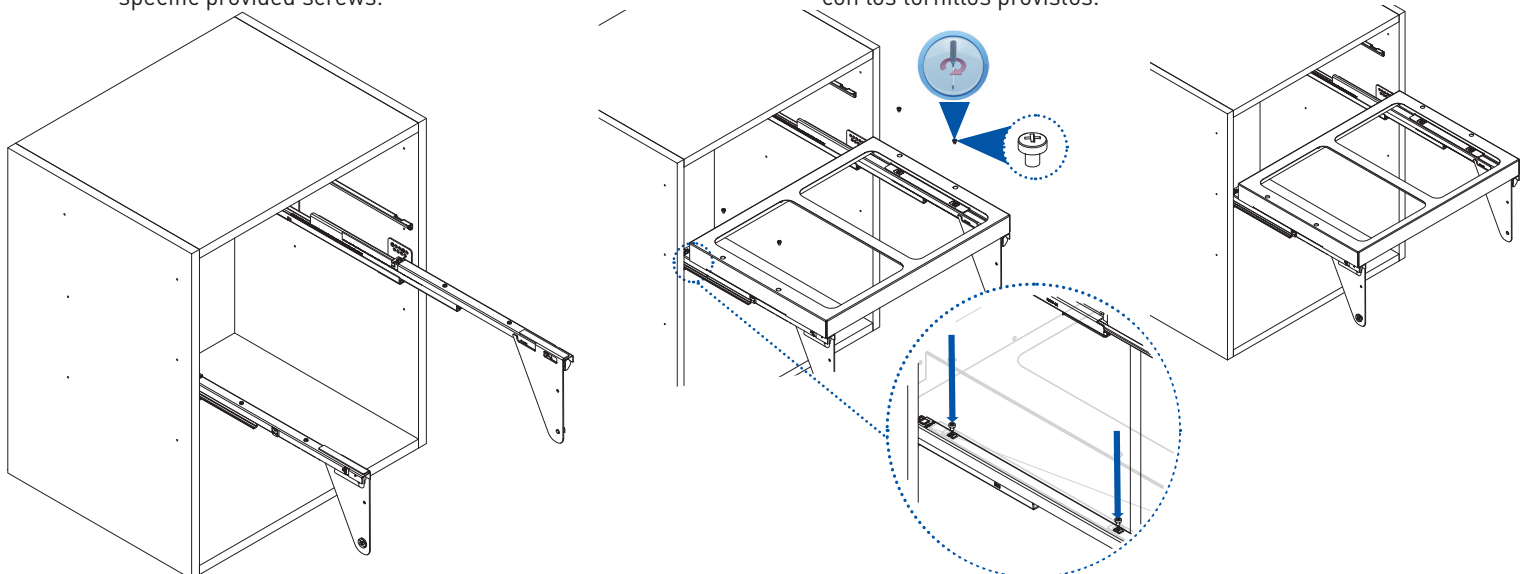

4

SOLO PER LA VERSIONE D450  
ONLY FOR D450 VERSION

Inserire i tappi L.  
Insert stopper L.  
Insérez les bouchon L.  
Introduzca los tapón L.

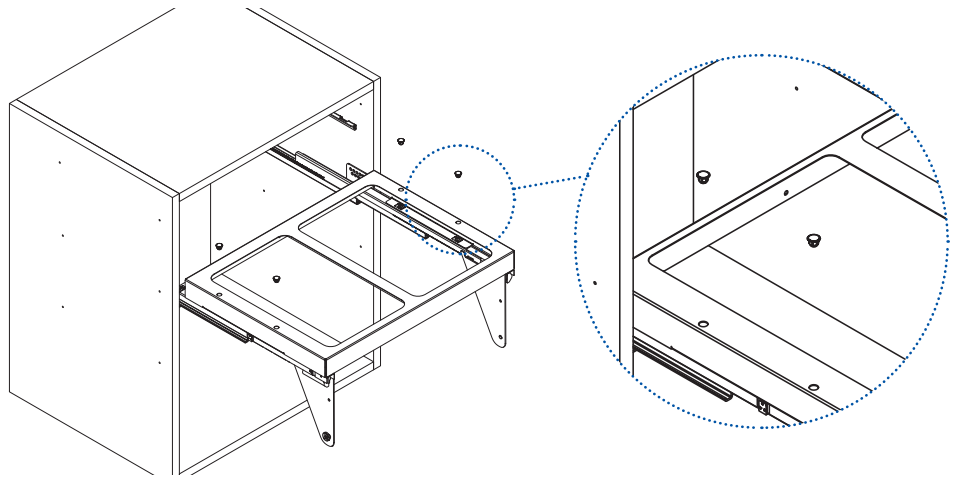

5

Fissare la coppia attacco antina G nell'anta, rispettando le quote.

Assemble the kit door fixing brackets G along with the according to the dimetions.

Fixez le kit pattes de fixation sur la porte G du meuble en respectant les dimensions.

Fijar el kit soportes de fijación de la puerta G en la puerta respetando las medidas.

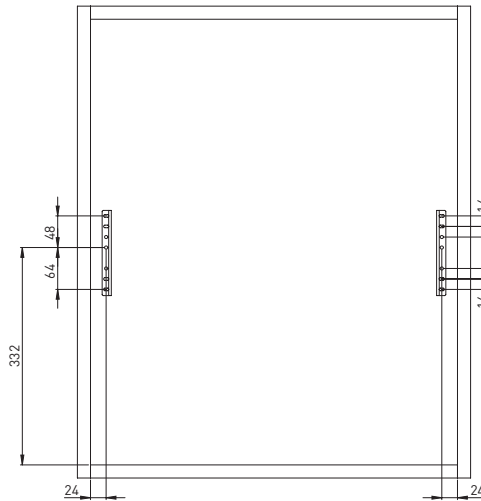

N°6 3,9x13

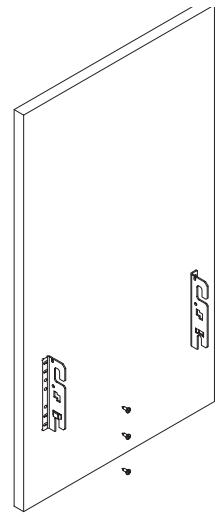

6

Inserire l'antina nei carter D e serrare il tutto a mezzo vite e rondella speciali.

Put the door into the carter D and fix them by using the specific screw and washer.

Insérez le kit carter pour la glissière D et fixez tout avec la vis et la rondelle spécifiques.

Colocar la puerta en los carter D y apretar todo con el tornillo y la arandela específicos.

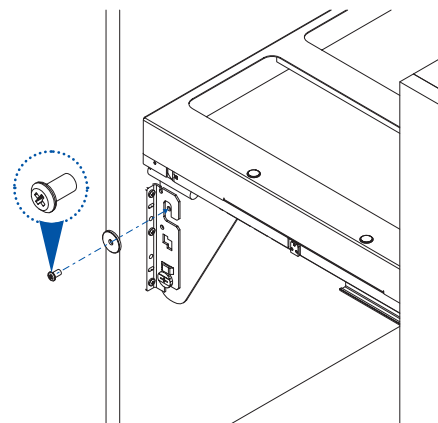
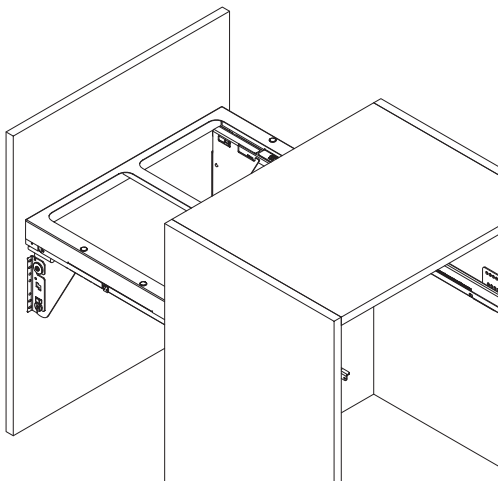

7

Effettuare la regolazione dell'anta.  
Adjust the furniture door.  
Réglez la porte du meuble.  
Ajustar la puerta del mueble.

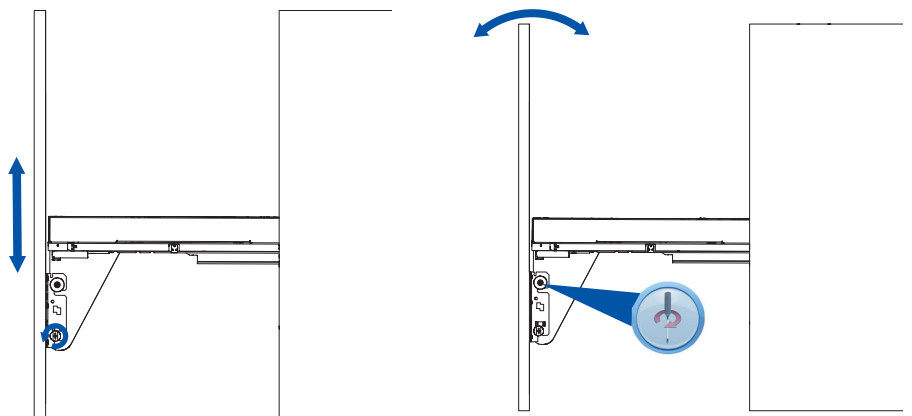



Inserire il coperchio B nelle lamiere reggi coperchio E e inserire la pattumiera F.

Put the lid B into the metal plate lid holder E and insert the wastebin F.

Insérez le couvercle B sur le support pour couvercle tôle E et insérez aussi la poubelle F.

Poner la tapa B sobre la placa de metal que sostiene la tapa E y colocar también el cubo de basura F.

