

PARTY

ISTRUZIONI DI MONTAGGIO ASSEMBLY INSTRUCTIONS

MODELLI:
MODELS:

411/78.1500.22 PARTY 600
411/78.1510.22 PARTY 900
411/78.1520.22 PARTY 1200

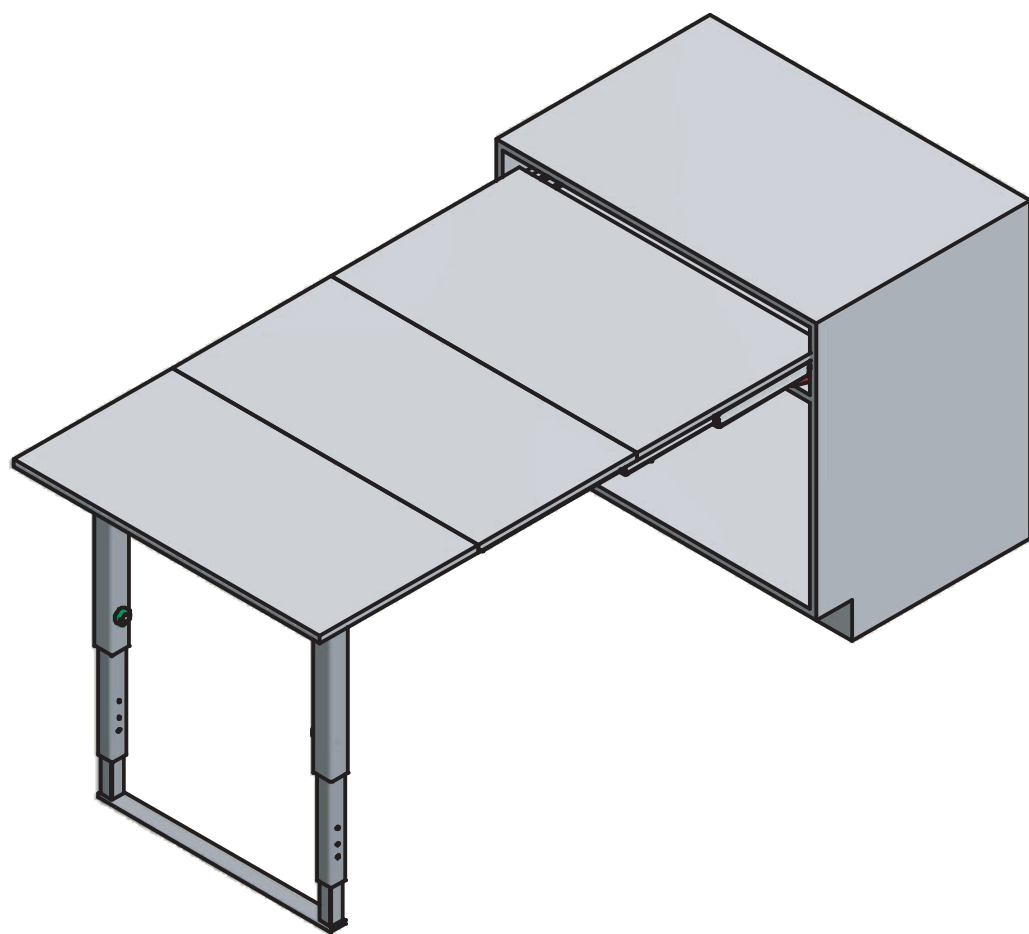

CONTENUTO DELLA CONFEZIONE INCLUDED IN THE PACKAGING

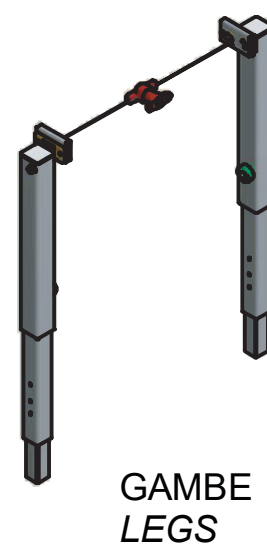

GAMBE
LEGS

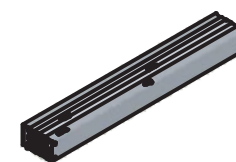

GUIDA
SLIDE

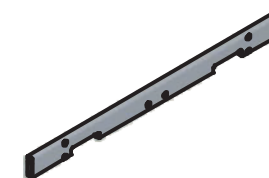

TRAVERSO
CONNECTING BAR



PIATTO INFERIORE
LOWER PLATE

SACCHETTO ACCESSORI - ACCESSORIES



A. Chiave esa. n.5 - n.5 Allen key



B. Chiave esa. n.4 - n.4 Allen key



C. Chiave esa. n.3 - n.3 Allen key



D. Distanziale per spalla - Side spacer (x 12)



E. Bussola M6 12x8 mm - M6 12x8 mm bush (x 12)



F. Perno - Pin (x 2)



G. Vite TCBCE M5x10 ISO 7380 - M5x10 BHCS screw (x 8)



H. Vite TCCE M6x12 - M6x12 SHCS screw (x 12)



I. Vite M6x25 trilobata - M6x25 self threading screw (x 4)



J. Vite TPS M6x16 - M6x16 FHCS screw (x 4)



K. Vite TPS M6x20 - M6x20 FHCS screw (x 2)



L. Vite TCCE M6x60 - M6x60 SHCS screw (x 4)

DIMENSIONI DI MASSIMA GENERAL DIMENSIONS

| CODICE - CODE | MODULO - MODULE | L1 - MIN/MAX (mm) | L2 (mm) | L3 (mm) | L4 (mm) | L5 (mm) |
|----------------|-----------------|-------------------|---------|---------|---------|---------|
| 411/78.1500.22 | 600 | 562/568 | 398 | 480 | 414 | 354.6 |
| 411/78.1510.22 | 900 | 862/868 | 698 | 780 | 714 | 654.6 |
| 411/78.1520.22 | 1200 | 1162/1168 | 998 | 1080 | 1014 | 954.6 |

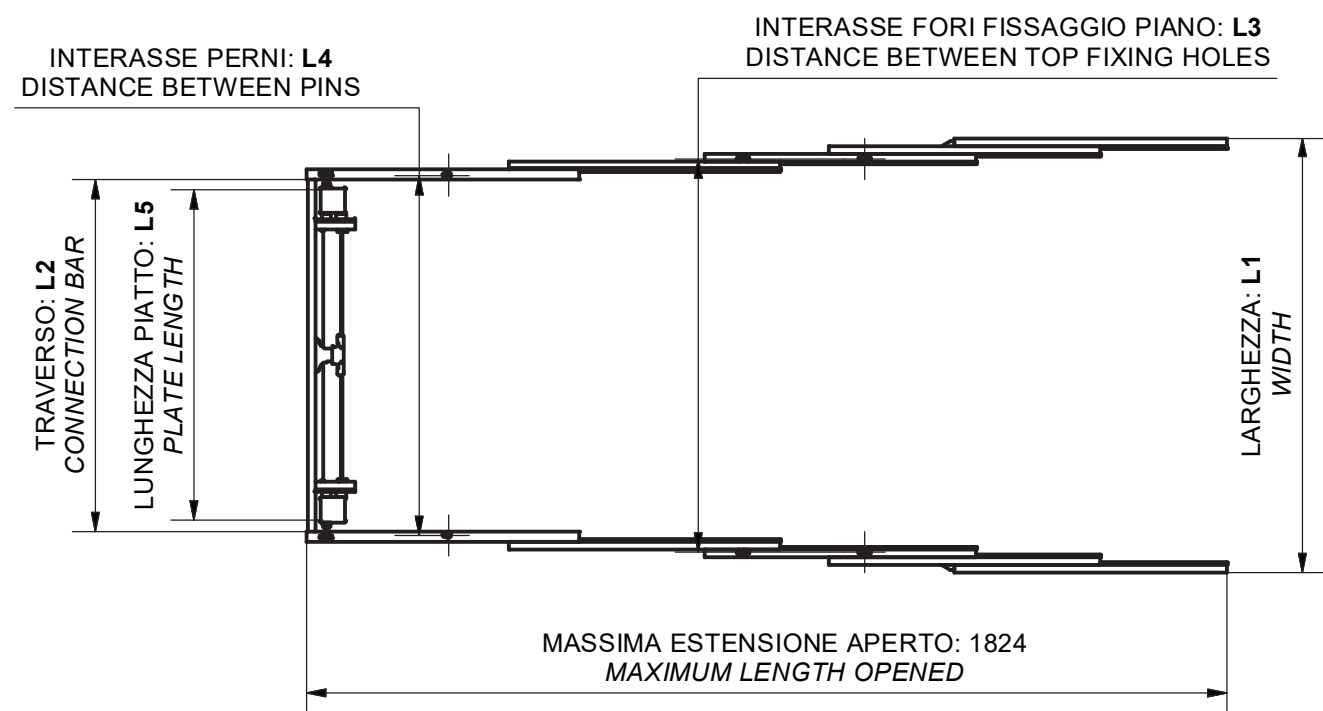
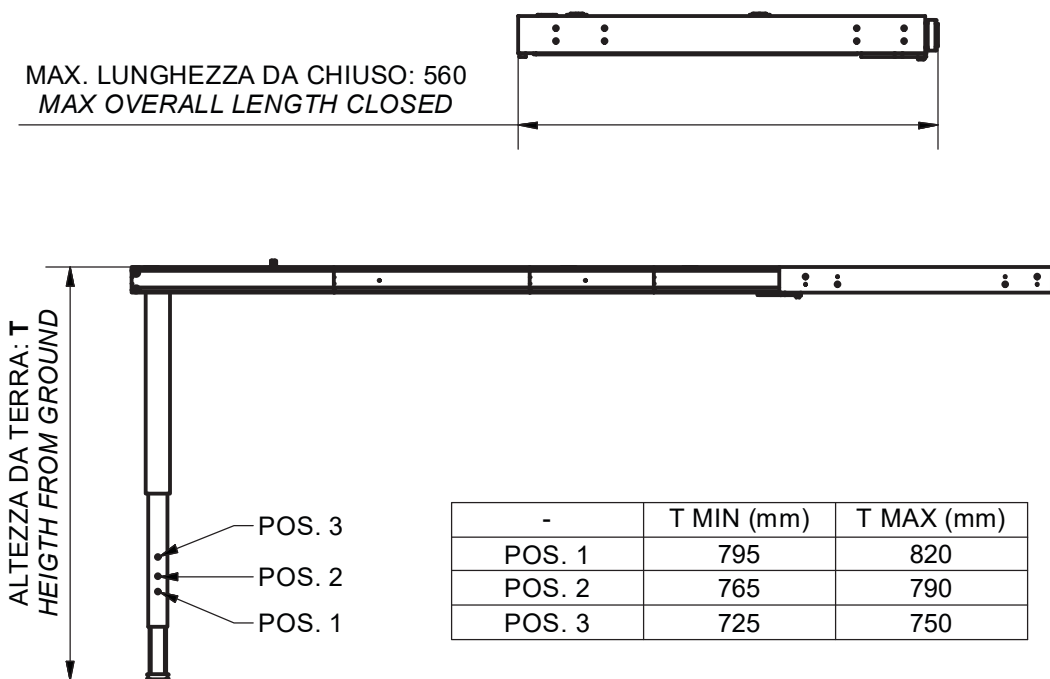

DIMENSIONI GENERALI MOBILE GENERAL CABINET DIMENSIONS

| DIMENSIONE - DIMENSION | SIMBOLO - SYMBOL | mm |
|---|------------------|-----------------------|
| ALTEZZA - HEIGHT | H | MIN: 150 |
| PROFONDITA' - DEPTH | P | MIN: 560 |
| LARGHEZZA - WIDTH | L | MIN: 562 MAX: 1168 |
| SPESSORE SPALLA - SIDE THICKNESS | S1 | 16-19 |
| SPESSORE PIANI - TOP THICKNESS | S | MIN: 16 |
| LARGHEZZA PIANI - TOP WIDTH | Z | L-5 |
| APERTURA PIANI - TOP OPENING | E | 1380 |
| APERTURA MECCANISMO - MECHANISM OPENING | C | 1275 |
| ALTEZZA DA TERRA - HEIGHT FROM GROUND | T | 725-820 |

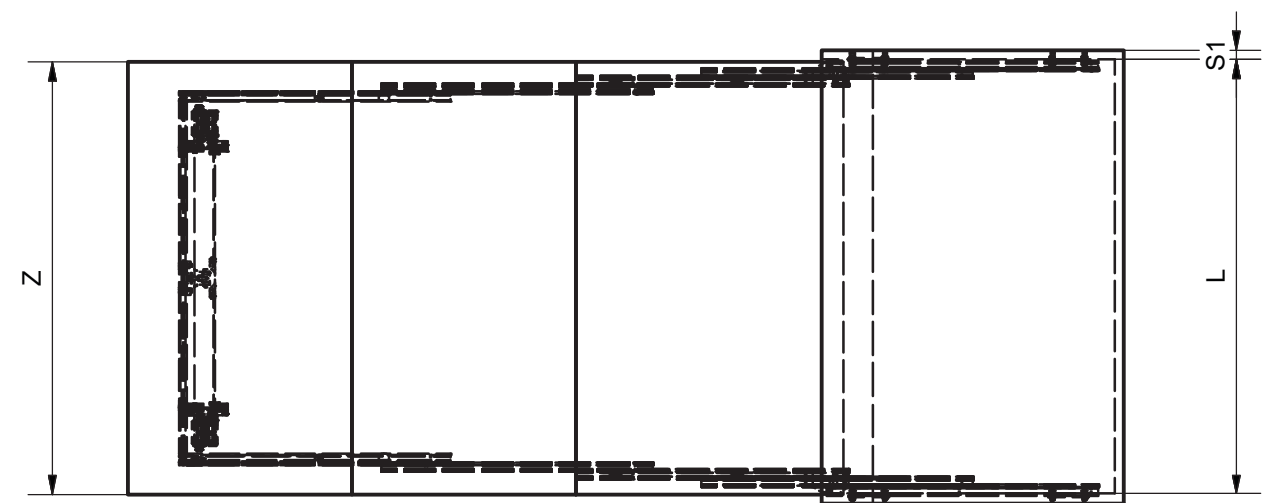
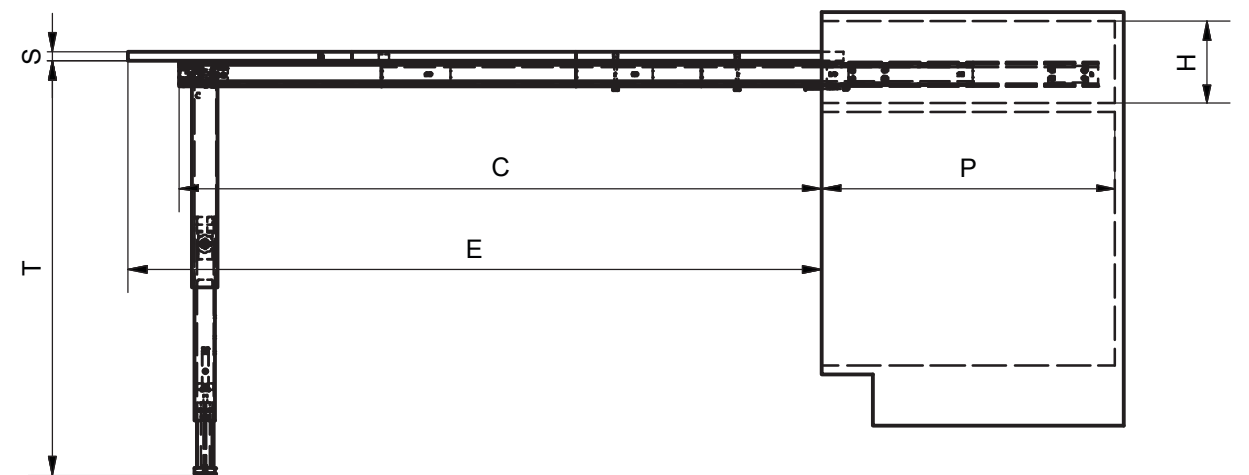

POSIZIONE FORI CABINET CABINET POSITION HOLES

Per spalle di spessore < 20 mm usare i distanziali per spalla
For cabinet sides < 20 mm use side spacers

- Spalla/Side: 20 mm - 0 distanziale/spacer
- Spalla/Side: 19 mm - 1 distanziale/spacers
- Spalla/Side: 18 mm - 2 distanziale/spacers
- Spalla/Side: 17 mm - 3 distanziale/spacers
- Spalla/Side: 16 mm - 4 distanziale/spacers
- Spalla/Side: 15 mm - 5 distanziale/spacers

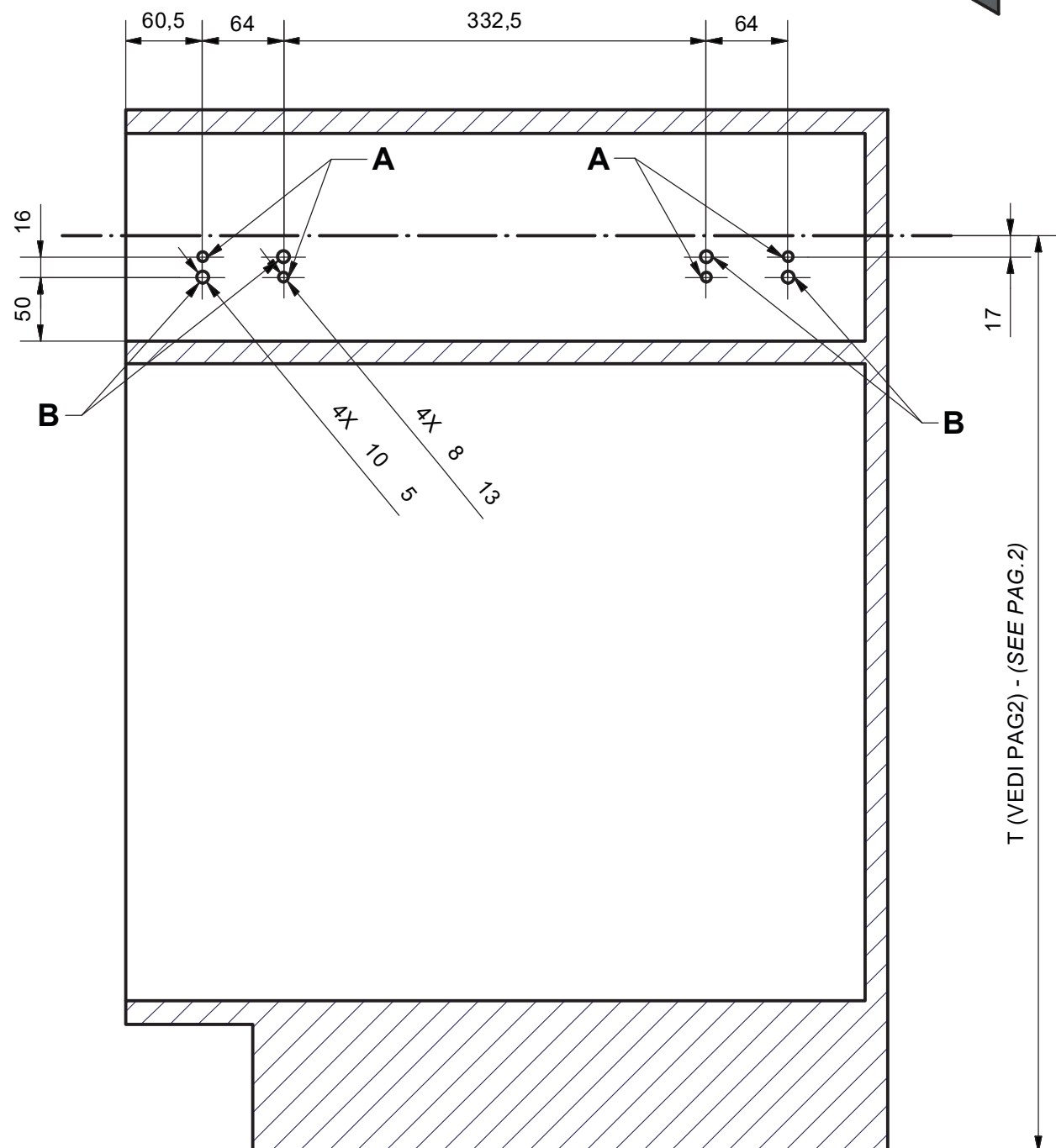
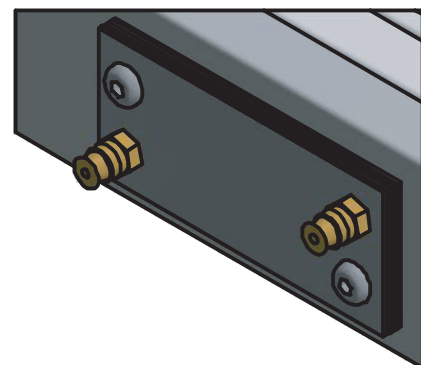

DIMENSIONE PIANI TOPS SIZE

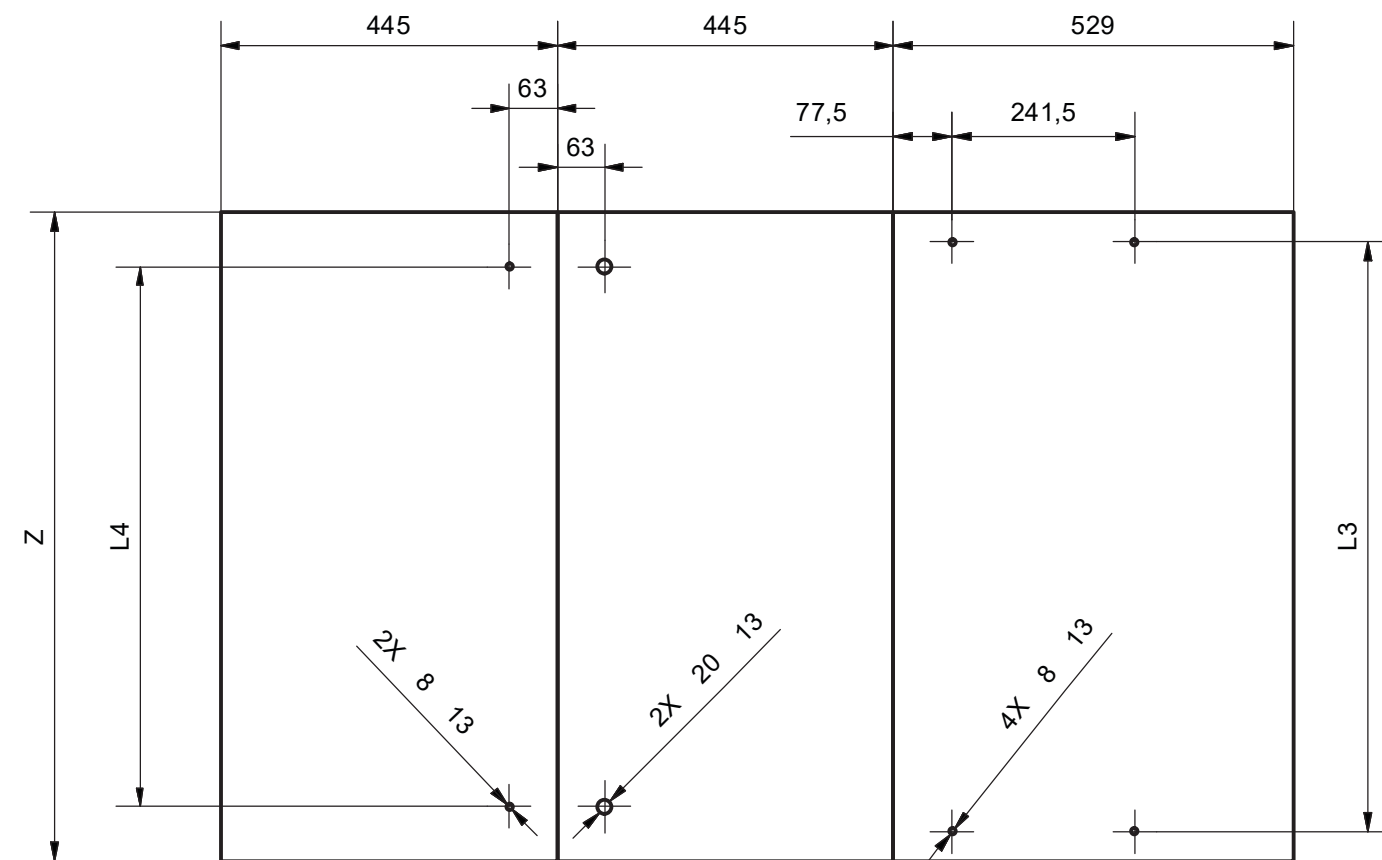

VISTA DAL BASSO - BOTTOM VIEW

POSIZIONE DELLE CERNIERE PER
FRONTALE CASSETTO

POSITION FOR THE HINGES THAT
HOLD THE DRAWER FRONT

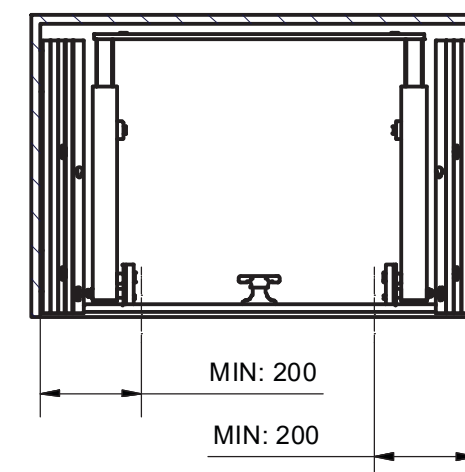

- A. Chiave esa. n.3 - n.3 Allen key
- D. Distanziale per spalla - Side spacer (x 12)
- E. Bussola M6 12x8 mm - M6 12x8 mm bush (x 12)
- G. Vite TCBCE M5x10 - M5x10 BHCS screw (x 8)

MONTAGGIO DEL MECCANISMO

MOUNTING OF THE MECHANISM

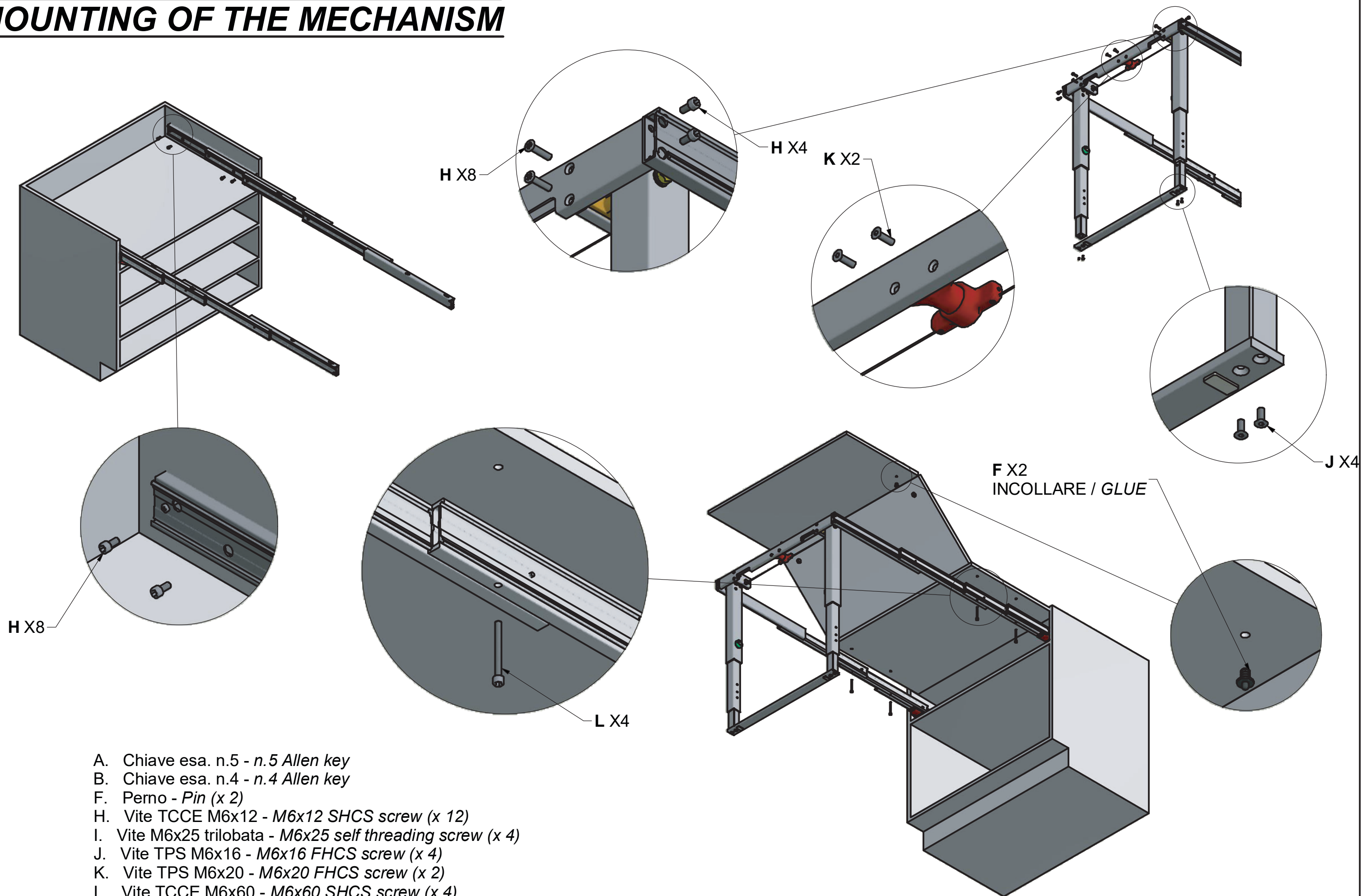

- A. Chiave esa. n.5 - n.5 Allen key
- B. Chiave esa. n.4 - n.4 Allen key
- F. Perno - Pin (x 2)
- H. Vite TCCE M6x12 - M6x12 SHCS screw (x 12)
- I. Vite M6x25 trilobata - M6x25 self threading screw (x 4)
- J. Vite TPS M6x16 - M6x16 FHCS screw (x 4)
- K. Vite TPS M6x20 - M6x20 FHCS screw (x 2)
- L. Vite TCCE M6x60 - M6x60 SHCS screw (x 4)

MONTAGGIO E REGOLAZIONE ALTEZZA GAMBE LEGS ASSEMBLY AND HEIGHT REGULATION

Inserire in questi fori la chiave da 4 per ruotare grano che permette regolazione della altezza della gamba di circa 25 mm

Insert in these holes the n. 4 allen key to allow leg height regulation of about 25 mm

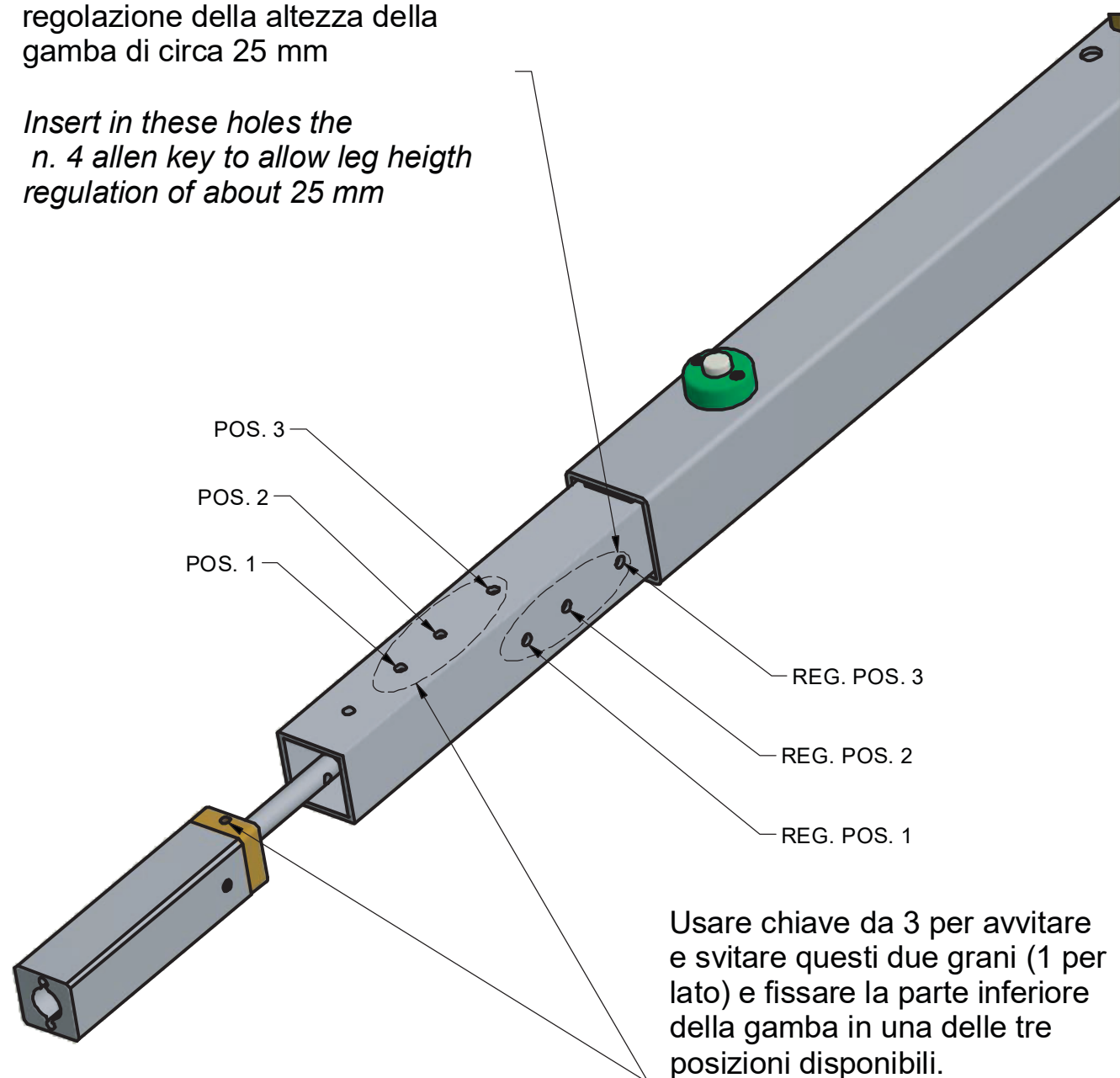

Usare chiave da 3 per avvitare e svitare questi due grani (1 per lato) e fissare la parte inferiore della gamba in una delle tre posizioni disponibili.

Use the n. 3 allen key to screw and unscrew this grain and positioning the lower part of the leg in one of the three allowable positions

COME GIRARE ED ESTENDERE LA GAMBA HOW TO TURN AND EXTEND THE LEG

A - Per ruotare le gambe, girare la maniglia tirando le due funi collegate alle gambe
To turn the legs, rotate the handle pulling the two ropes joined to the legs.

B - Per far rientrare la parte inferiore delle gambe spingere i pulsanti indicati
To close the inferior part of the legs, push the indicate buttons.

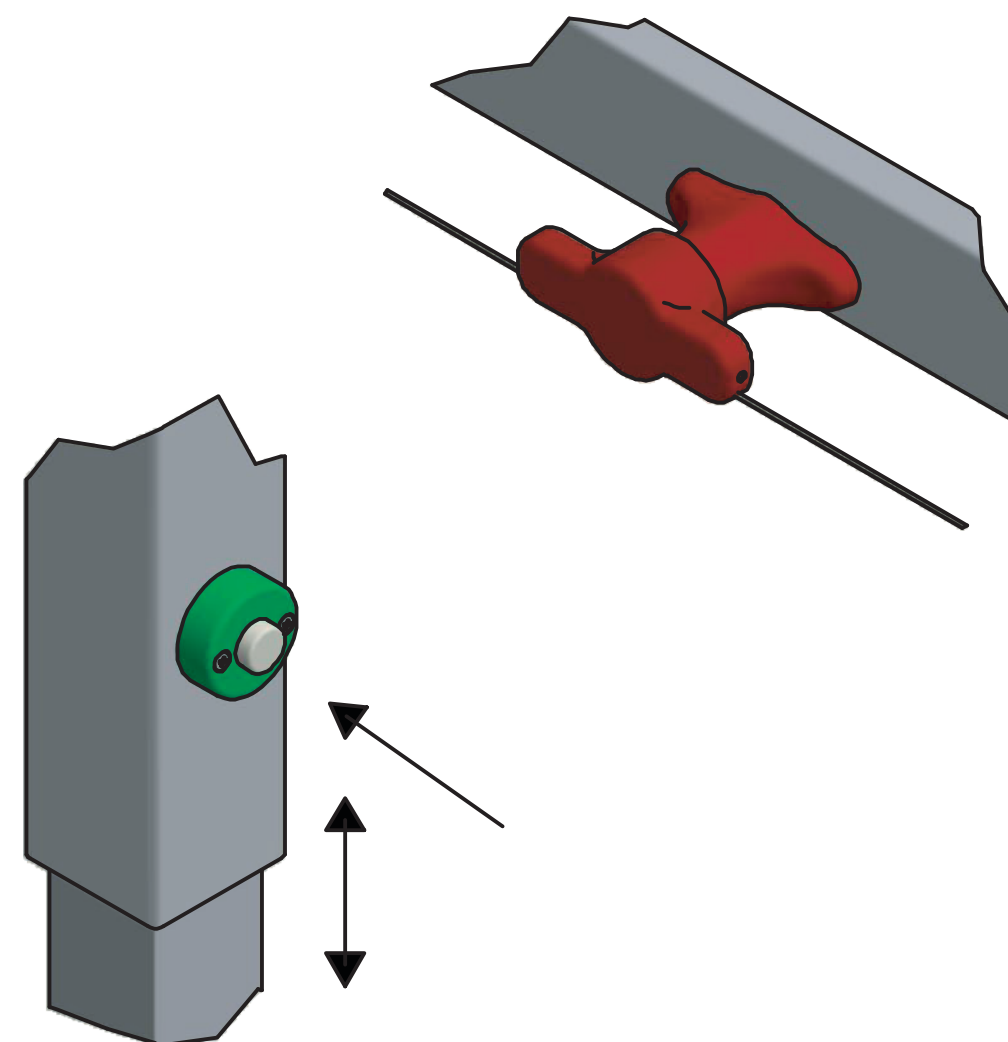

SEQUENZA DI FUNZIONAMENTO

FUNCTIONING SEQUENCE

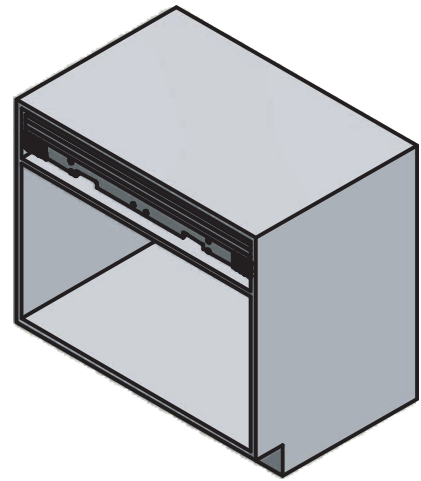

CHIUSO
CLOSED

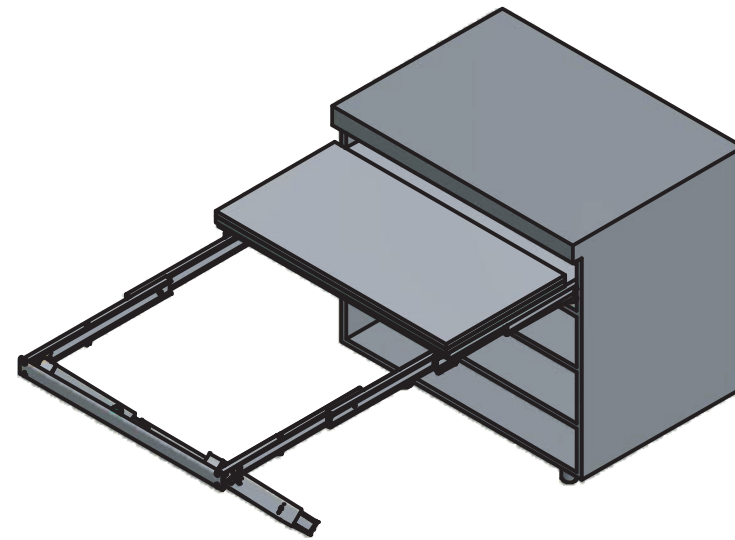

APERTURA DELLE GUIDE
SLIDES OPENING
SBLOCCO E ROTAZIONE DELLA GAMBA
LEG RELEASE AND ROTATION

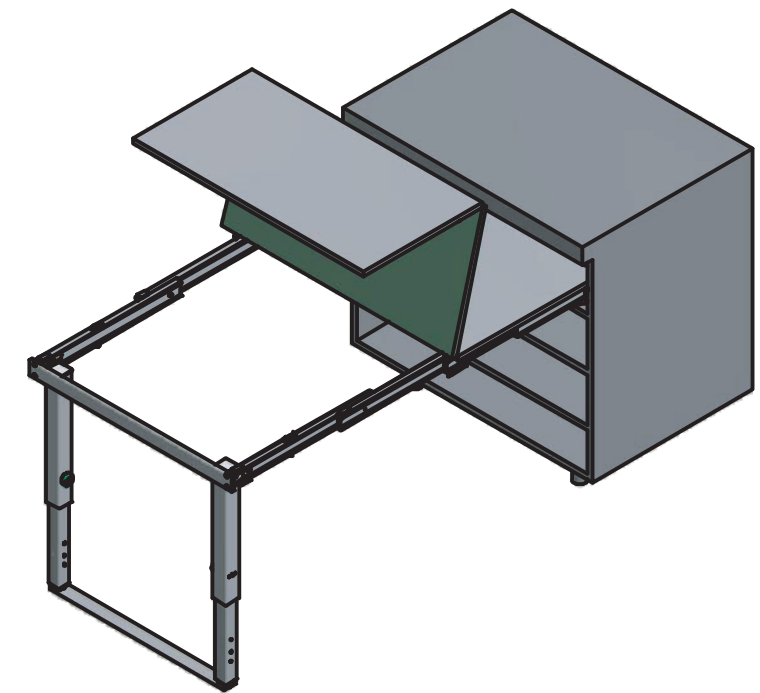

ESTENSIONE E BLOCCO DELLA GAMBA
LEG EXTENTION AND LOCK
APERTURA DEI PIANI
PLANES OPENING

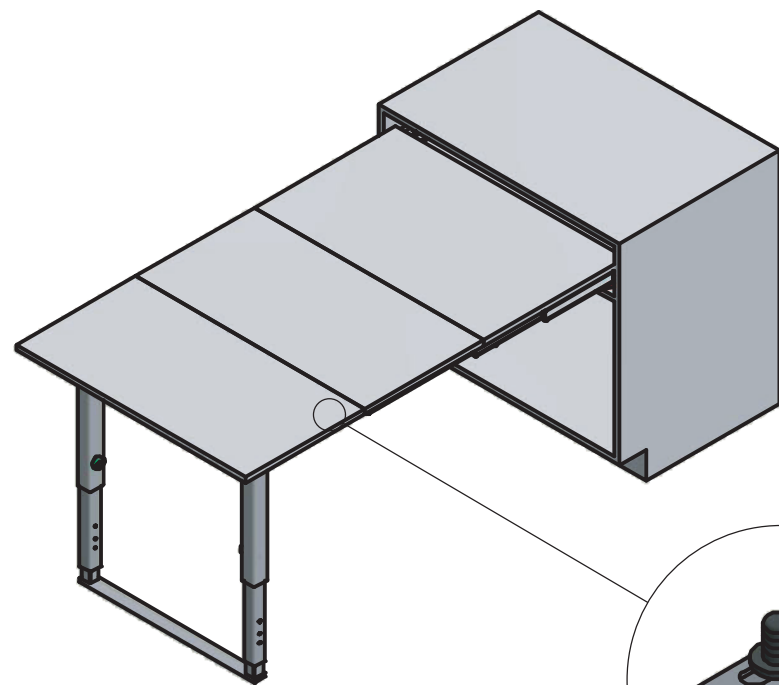

APERTO
OPENED

Per chiudere il meccanismo
spingere le due leve rosse in
plastica verso l'interno
*To close the mechanism push
toward the inside the two red
plastic parts*

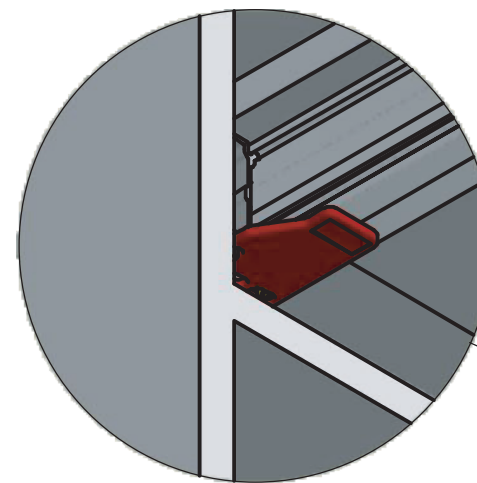

Bloccare il piano spingendo le gambe
verso l'interno, il perno entra nella sede
*Lock the floor by pushing the legs
inward, the pin enters the seat*
Sbloccare il piano tirando le gambe, il
perno esce dalla sua sede
*Unlock the floor by pulling the legs, the
pin comes out of its seat*

