

Maxima Corner Optima Left 800/450 - 900/500

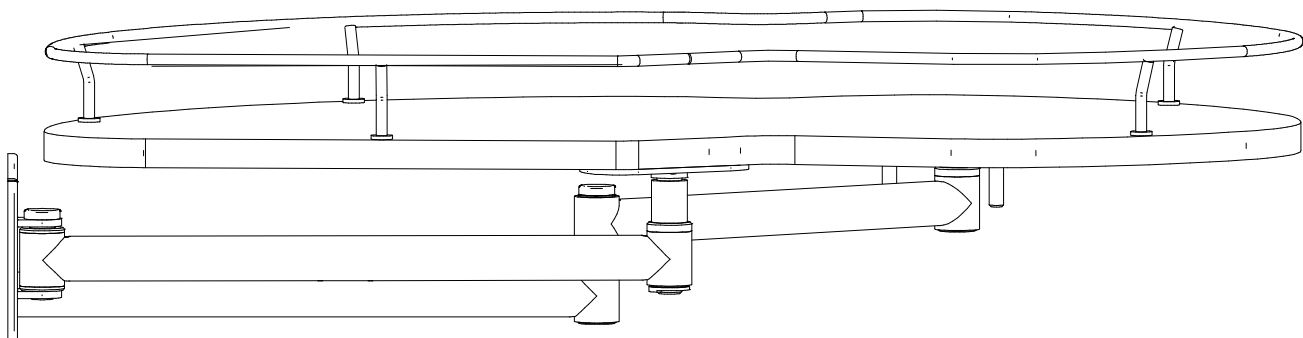

Option 1

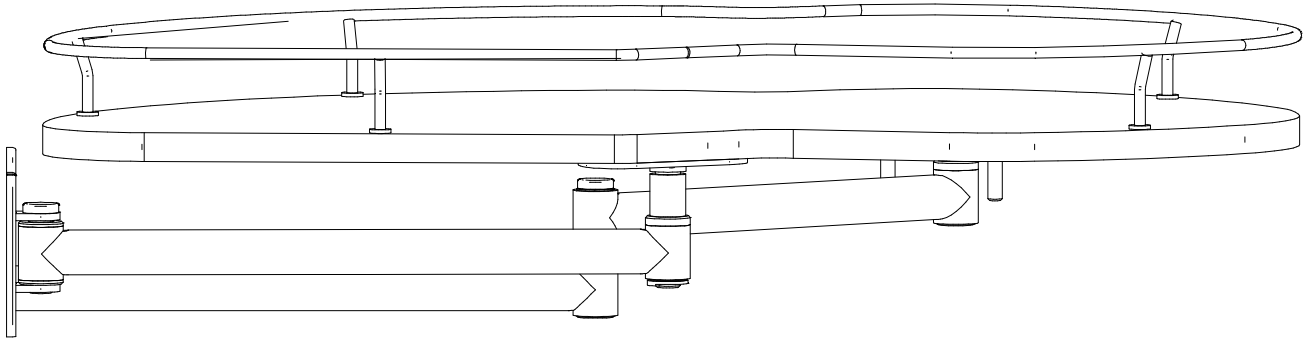
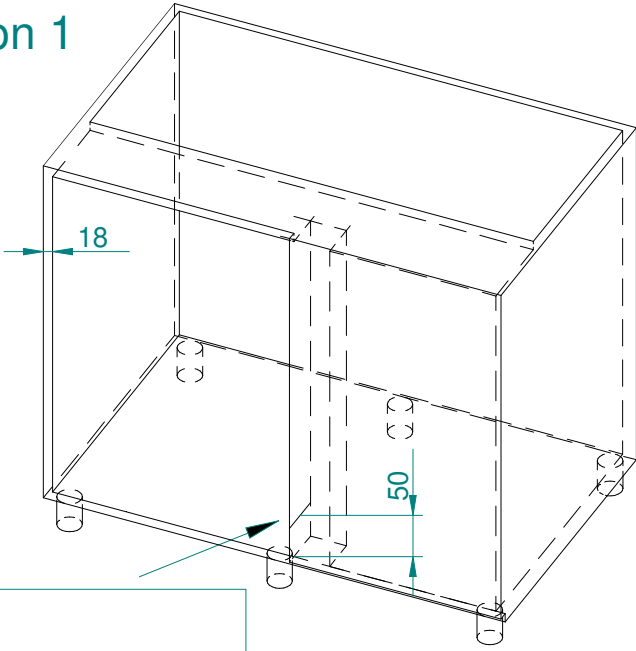

Distance to the middle part of hinge mounting plate

Option 2

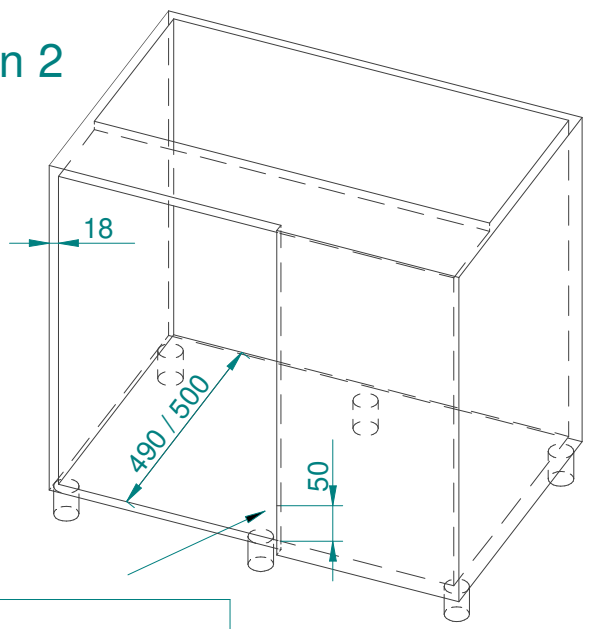

Distance to the middle part of hinge mounting plate

Optima 800

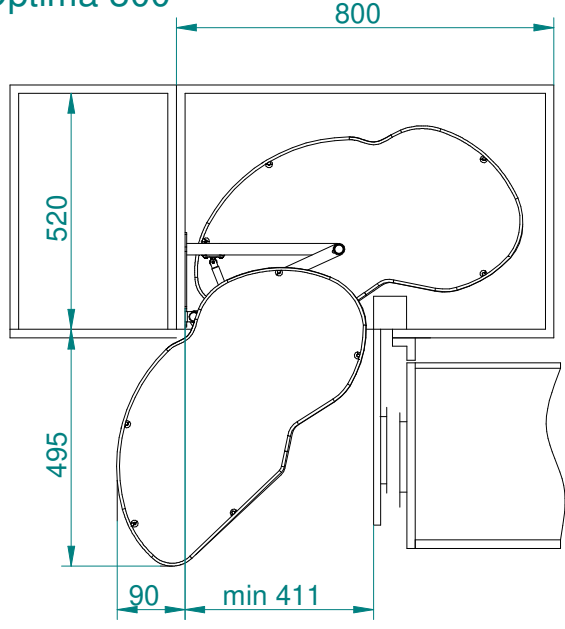

Optima 800

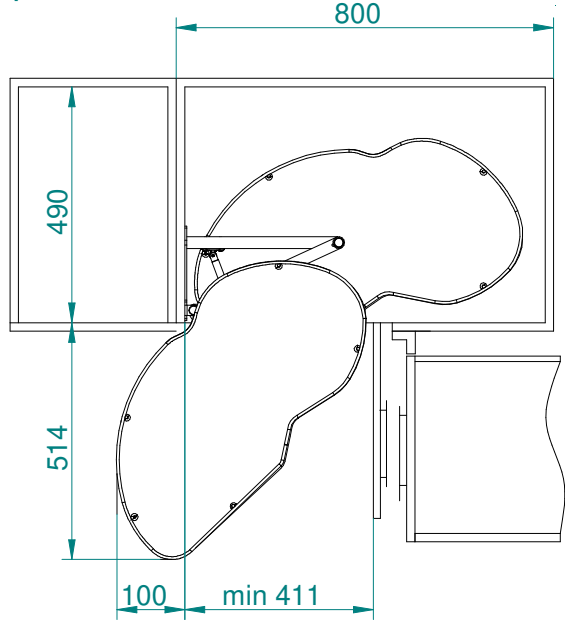

Optima 900

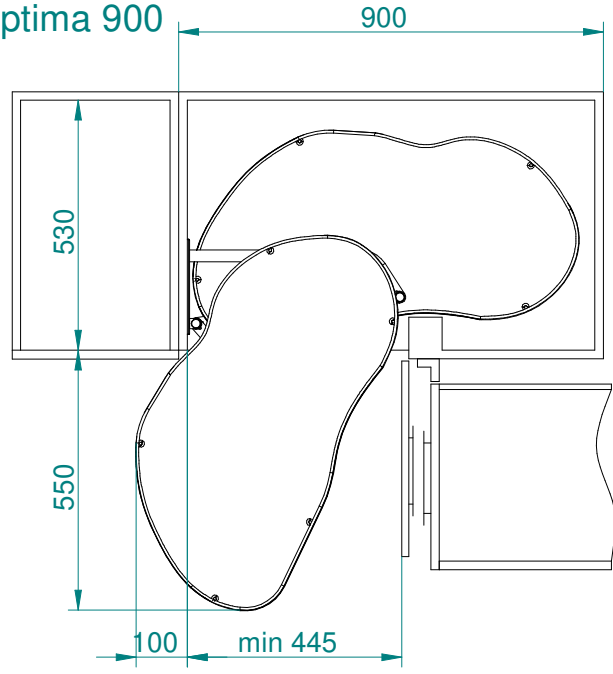

Optima 900

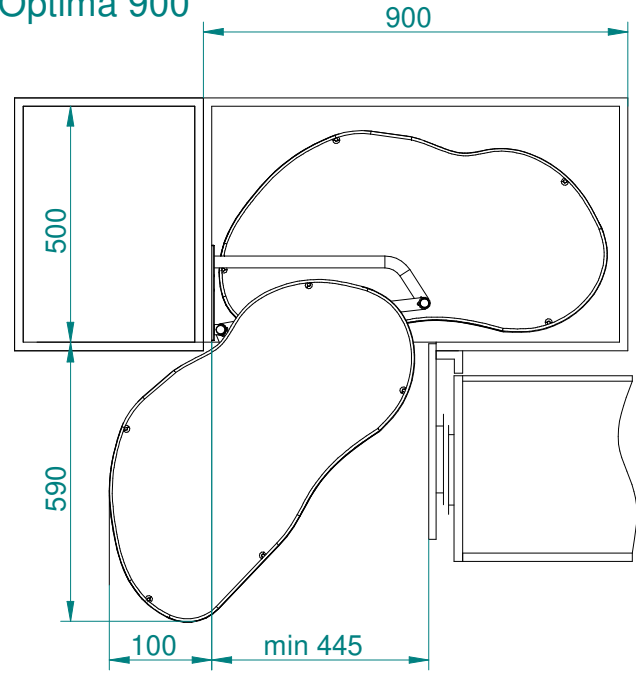

Optima 800

1

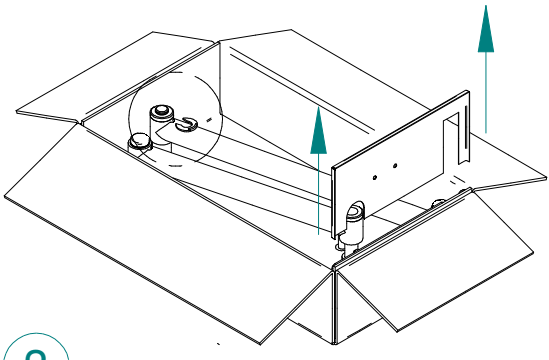

2

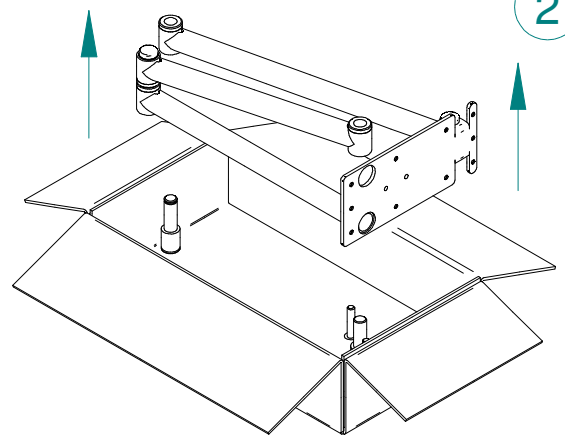

3

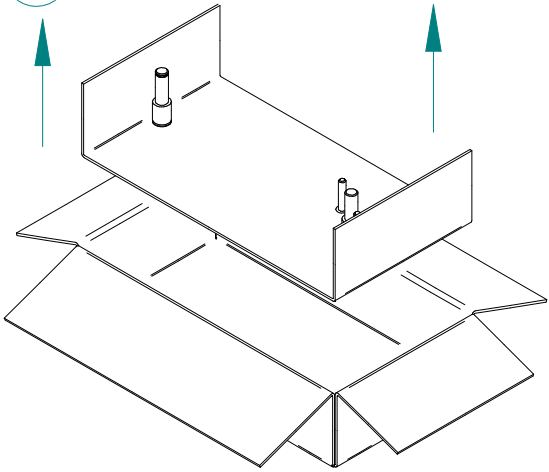

4

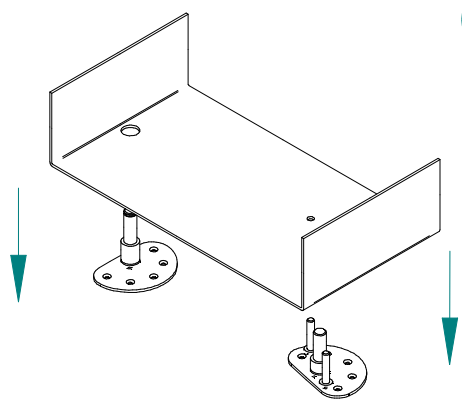

Optima 900

1

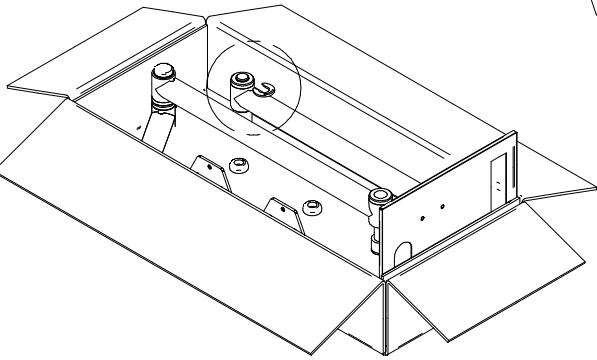

2

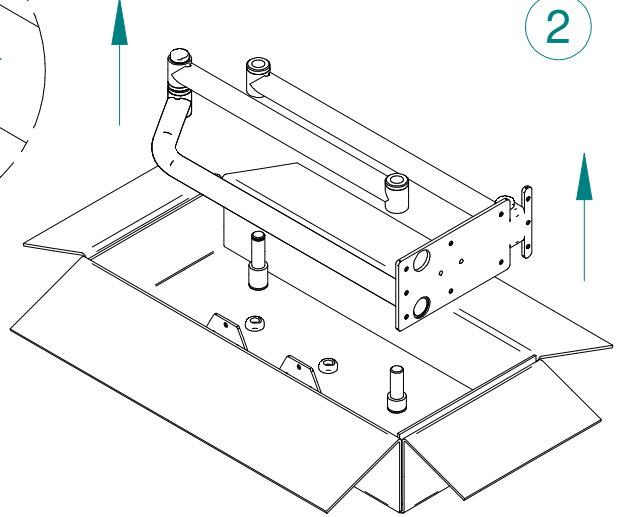

3

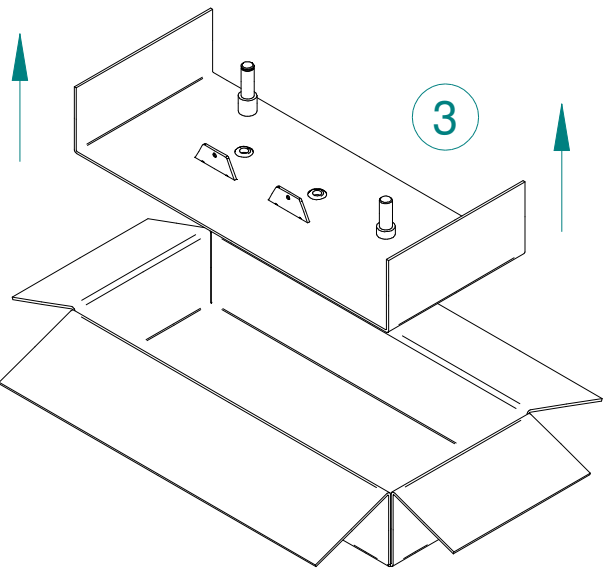

4

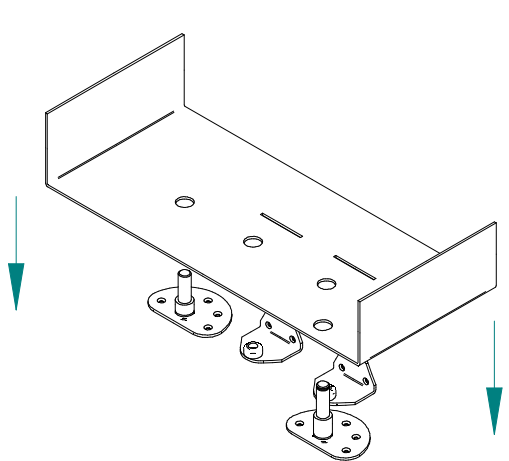

Corner Optima 800

Corner Optima 900

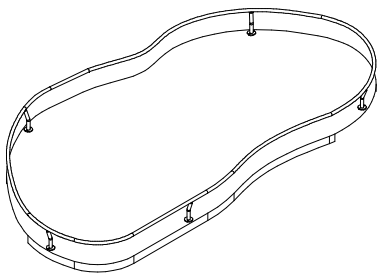

A1
x2

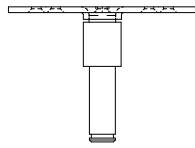

C1
x2

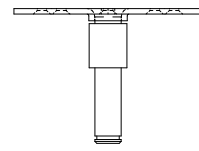

C1
x2

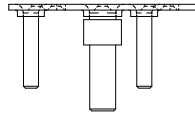

C2
x2

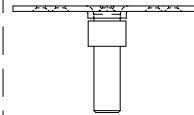

C2
x2

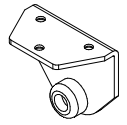

D1
x4

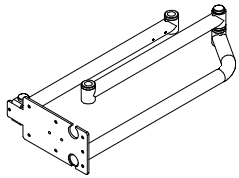

B1
x2

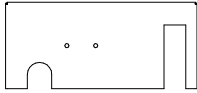

B2
x2

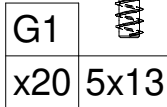

F1
x2

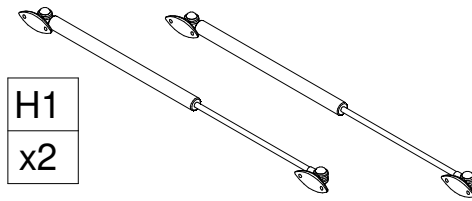
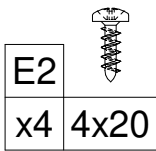
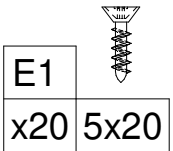
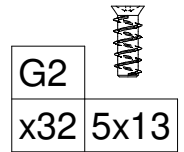

H1
x2

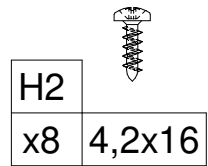

1

Opcja 1 Option 1

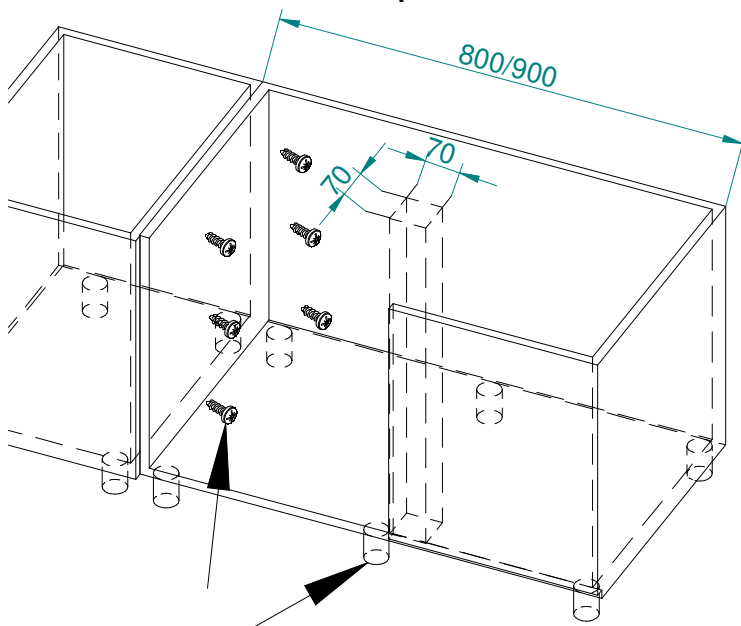

Opcja 2 Option 2

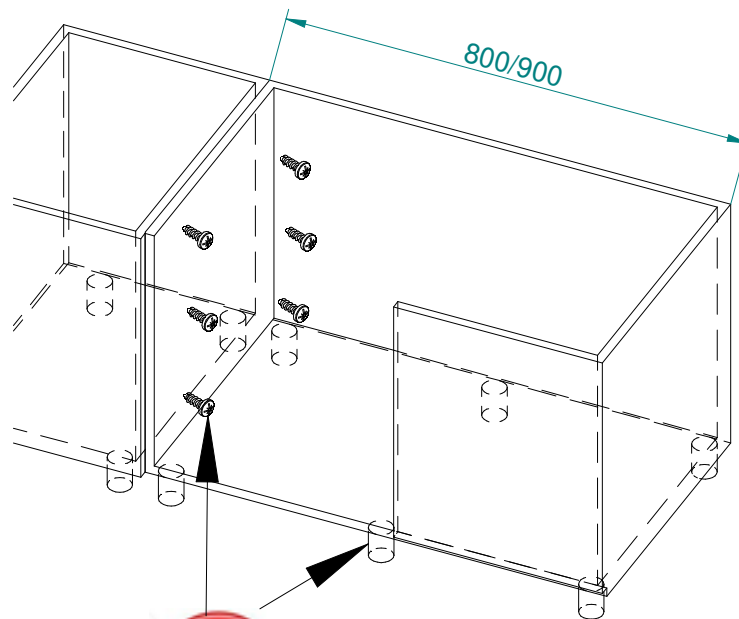

2



Corner Optima 800

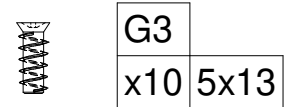
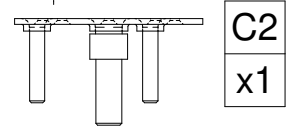
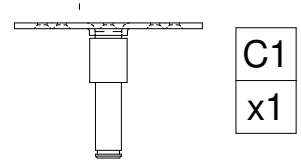
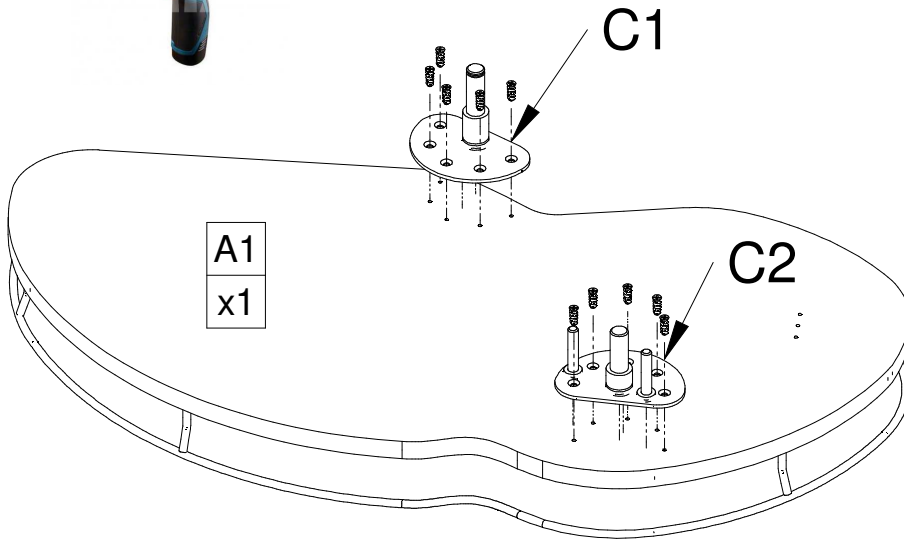

2



Corner Optima 900

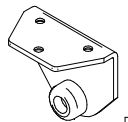
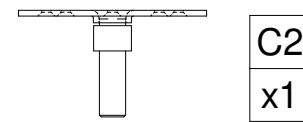
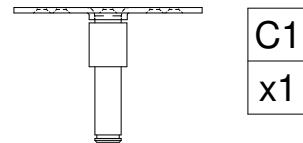
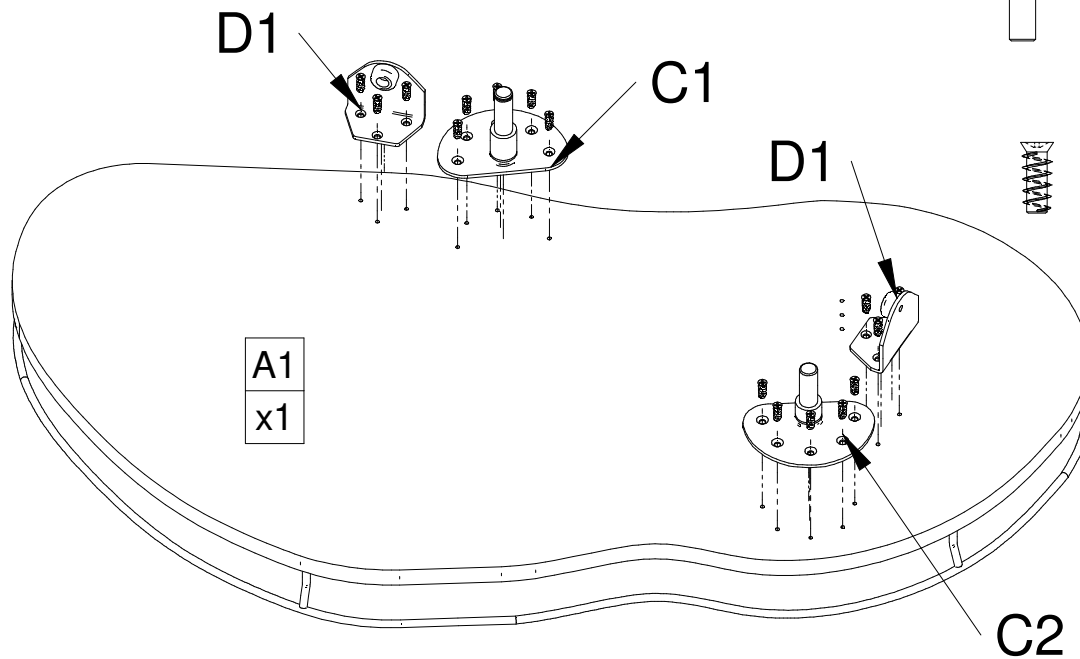

D1
x2

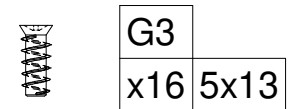

3

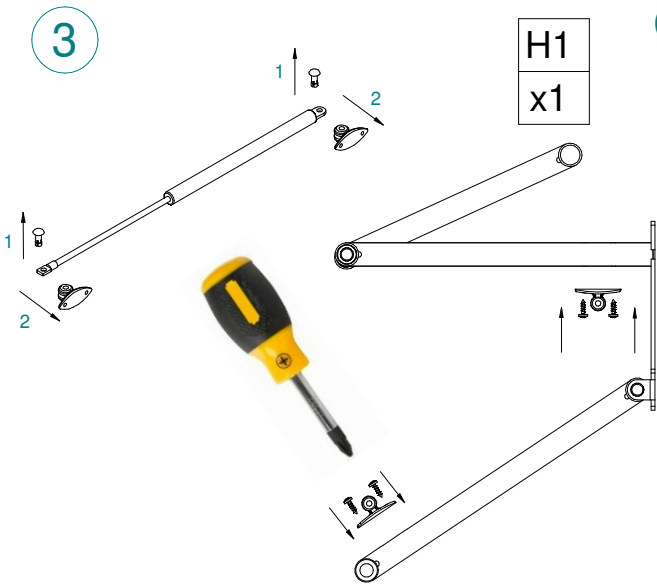

Corner Optima 800

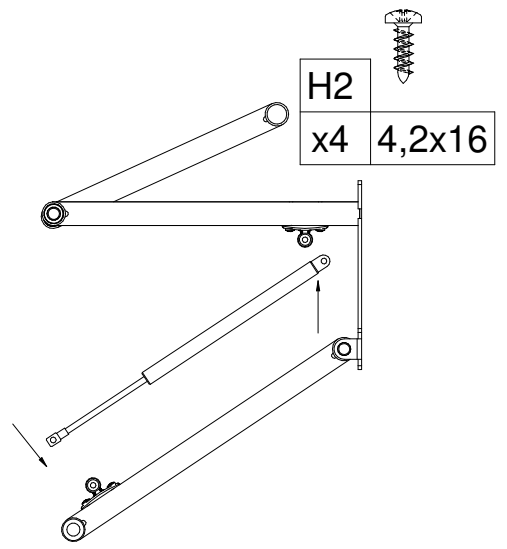

3

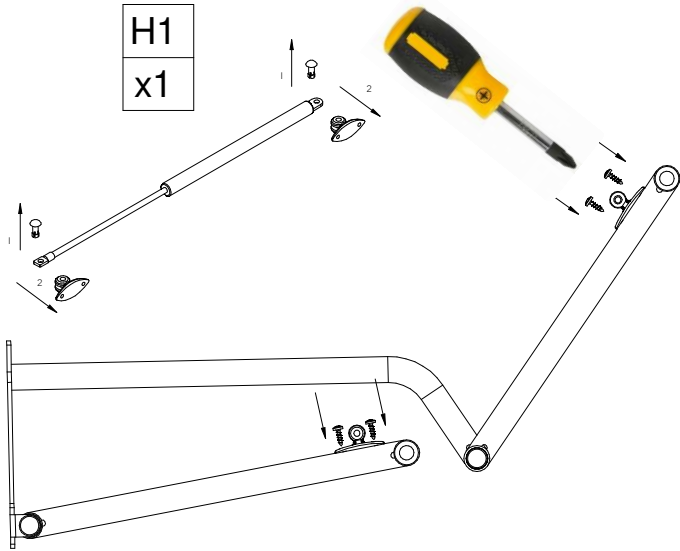

Corner Optima 900

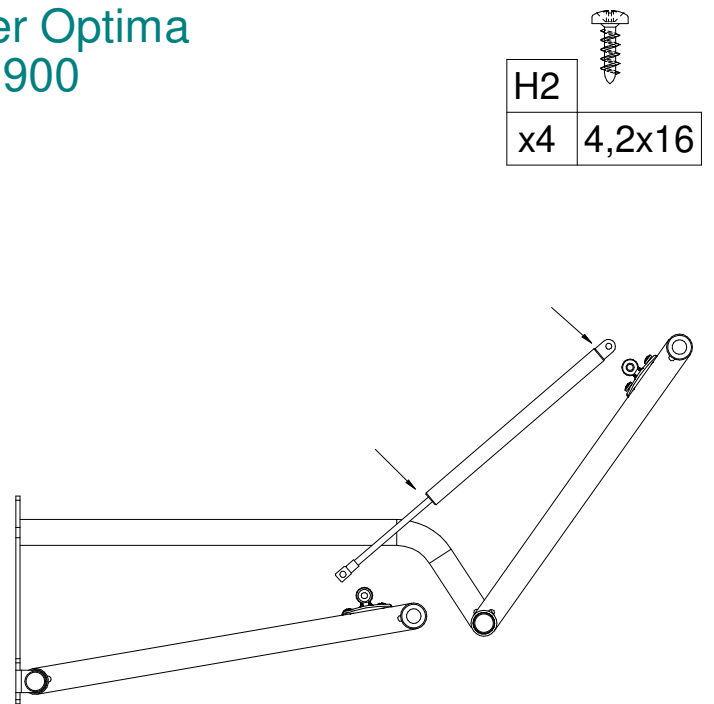

4

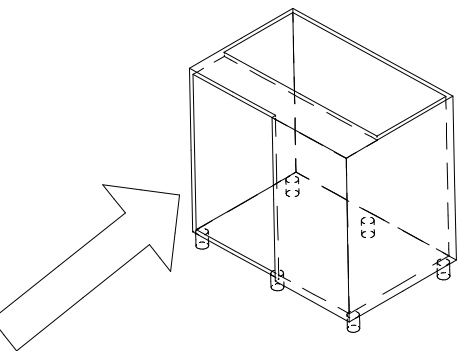

Opcja 1 Option 1

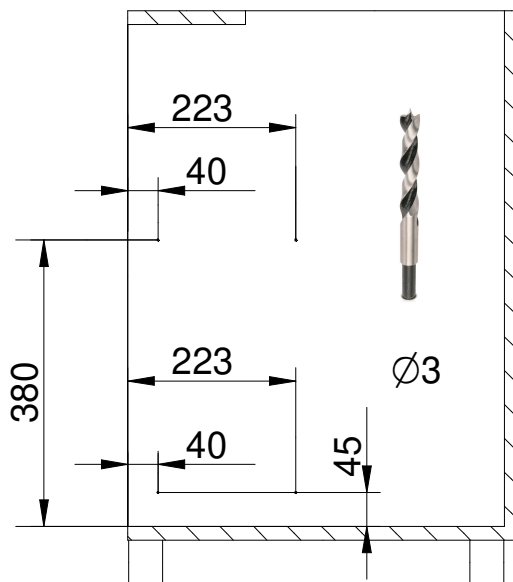

Opcja 2 Option 2

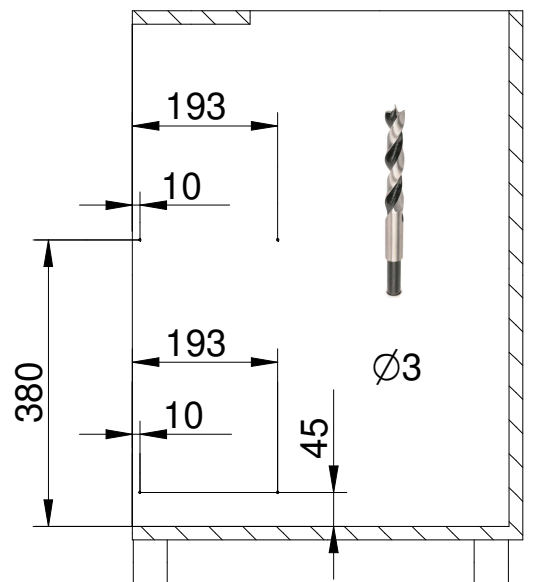

5

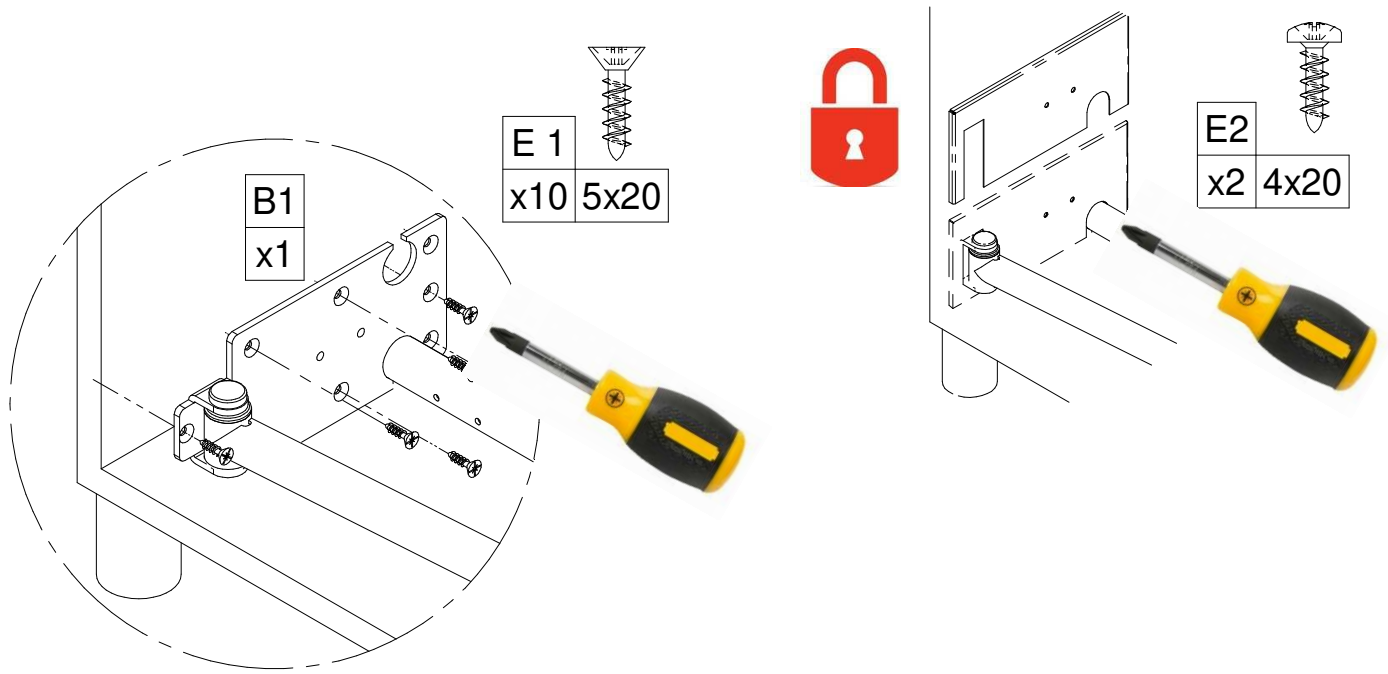

6

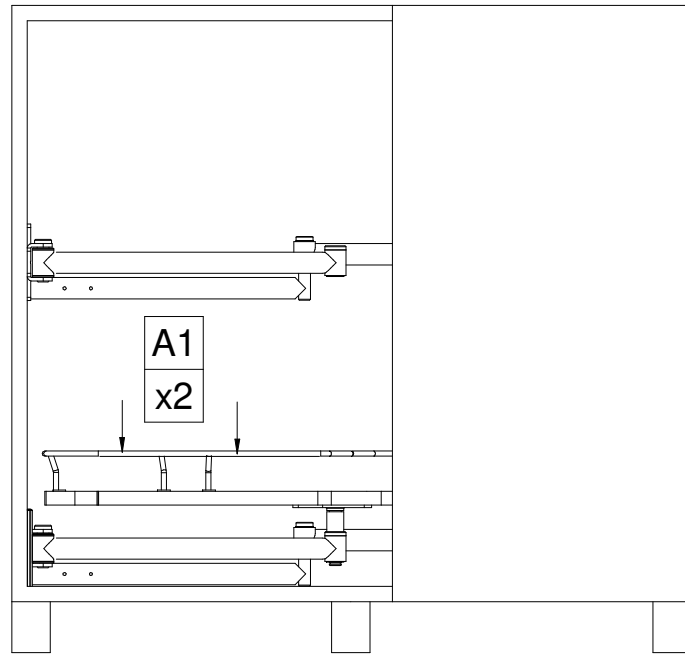

7

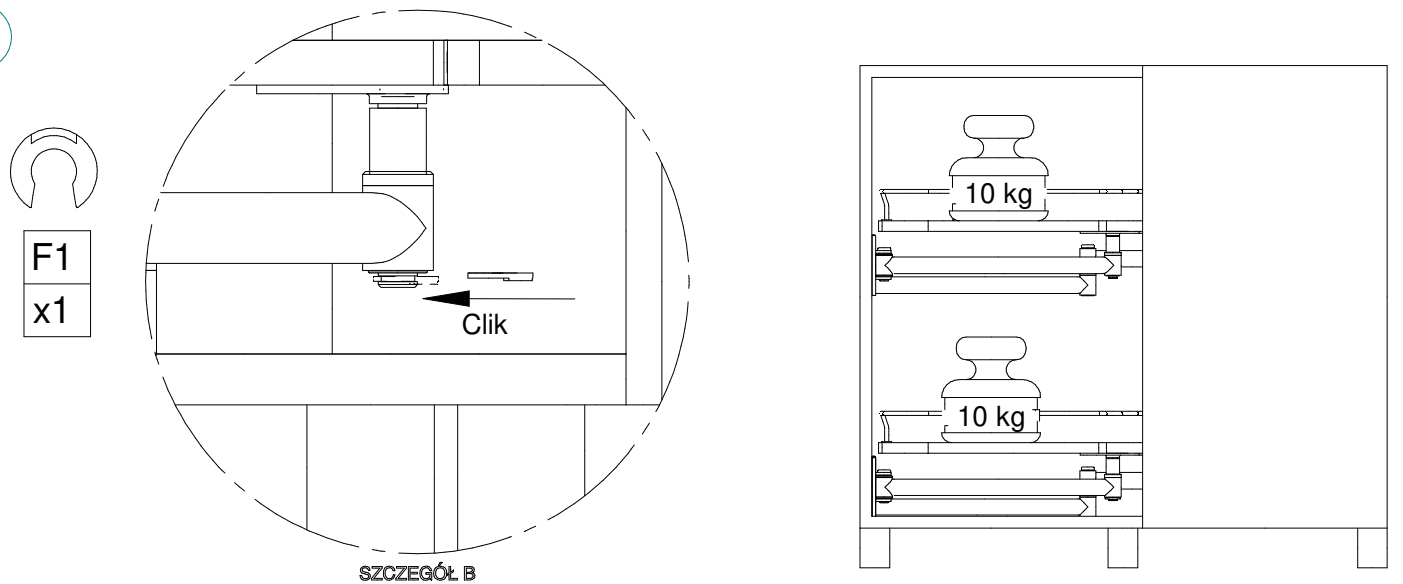

Symbole / Symbols / Symbole / Символы/ Vysvětlivky



Uwaga / Warning / Achtung / Внимание/ Pozor



Nieprawidłowo / Incorrect / Nicht korrekt / Неправильно/ Nesprávne



Prawidłowo / Correct / Korrekt / Правильно/ Správne



Przykręcić / Secured / Fixieren / Прикрутить/ Dotáhnout



Zluzować / Release / Lösen / Рыхлить/ Povolit'



Nie używać wkrętarki akumulatorowej / Do not use a cordless screwdriver / Keinen akkuschauber verwenden / Не используйте аккумуляторную отвертку/ Nepoužívať aku-skrutkovač



Użyć wkrętaka Pz2 / Use a PZ2 screwdriver / PZ2-Schraubendreher verwenden / С помощью отвертки Pz2/ Použiť skrutkovač Pz2



Element występuje opcjonalnie / Optional part / Optionales Element / Элемент является опциональным/ Položka je volitelná



Dźwięk po wciśnięciu / Click sound after installation / Klick-Geräusch beim Einrasten / Звук после монтажа/ Zvuk po zatlačení

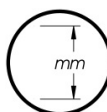

Wszystkie wymiary podane są w mm / All dimensions in mm / Alle Maße in mm / Все размеры в мм/ Odřízněte vhodným nástrojem



Należy odciąć odpowiednim narzędziem / sollte ein geeignetes Werkzeug eschnitten / It must be cut off by the right tool / Надо обрезать надлежащим инструментом/ Odřízněte vhodným nástrojem

Aby zapobiec przewróceniu się mebla, należy na stałe przymocować go do ściany. Sprawdź rodzaj i wytrzymałość ściany. Dobierz odpowiednie kołki i wkręty do rodzaju ściany. **Montaż musi zostać wykonany przez kompetentną osobę.** Prezentacje techniczne i dane wymiarowe na rysunkach są niewiążące. Zmiany konstrukcyjne zastrzeżone .

To prevent falling down of the cabinet, it should be affixed to the wall. Please check type and durability of the wall. Choose appropriate rawplug and screws for the walls. Installation must be made by a specialist. Technical description and data on the drawings are non-binding. We reserve the rights to change the construction.

Um zu verhindern, den Schrank kippen, sollte es an die Wand dauerhaft befestigen werden. Überprüfen Sie die Art und Stärke der Wand. Montieren Sie die entsprechende Dübel und Schrauben für die Wände. Die Installation muss von einer sachkundigen Person durchgeführt werden. Technische Präsentationen und Daten Maßzeichnungen sind unverbindlich. Konstruktionsänderungen vorbehalten.

Для того, чтобы мебель не упала, обязательно прикрепите шкаф к стене. Проверьте вид и прочность стены. Подберите правильные для вида стены шканты и винты. Установку обязательно должен выполнить квалифицированный специалист. Технические презентации и чертежи условного характера, допустимые отклонения. Изготовитель имеет право внести изменения в конструкцию