

OPLA' FOLDING

ISTRUZIONI DI MONTAGGIO ASSEMBLY INSTRUCTIONS

MODELLI:
MODELS:

78.1700.25 F - OPLÀ FOLDING 600
78.1710.25 F - OPLÀ FOLDING 900
78.1720.25 F - OPLÀ FOLDING 1200

CONTENUTO DELLA CONFEZIONE INCLUDED IN THE PACKAGING

- GUIDE - *SLIDES*
- TRAVERSO - *BAR*
- ASTA - *ROD*
- STAFFE - *BRACKETS*

SACCHETTO ACCESSORI - *ACCESSORIES*

- A. Chiave esa. n.5 - *n.5 Allen key*
- B. Chiave esa. n.4 - *n.4 Allen key*
- C. Molla - *Spring (x2)*
- D. Ammortizzatore - *Dumper (x2)*
- E. Bussola Ø10x11 - *Ø10x11 Bush (x12)*
- F. Rondella Ø20x3 - *Ø20x3 Washer (x4)*
- G. Vite truciolare 4x16 - *4x16 FHP screw (x12)*
- H. Vite TCCE M5x6 - *M5x6 SHCS screw (x6)*
- I. Vite TPS M5x12 - *M5x12 FHCS screw (x2)*
- J. Vite TCCE M6x12 - *M6x12 SHCS screw (x4)*

REGOLAZIONE PIANO TOP ADJUSTMENT

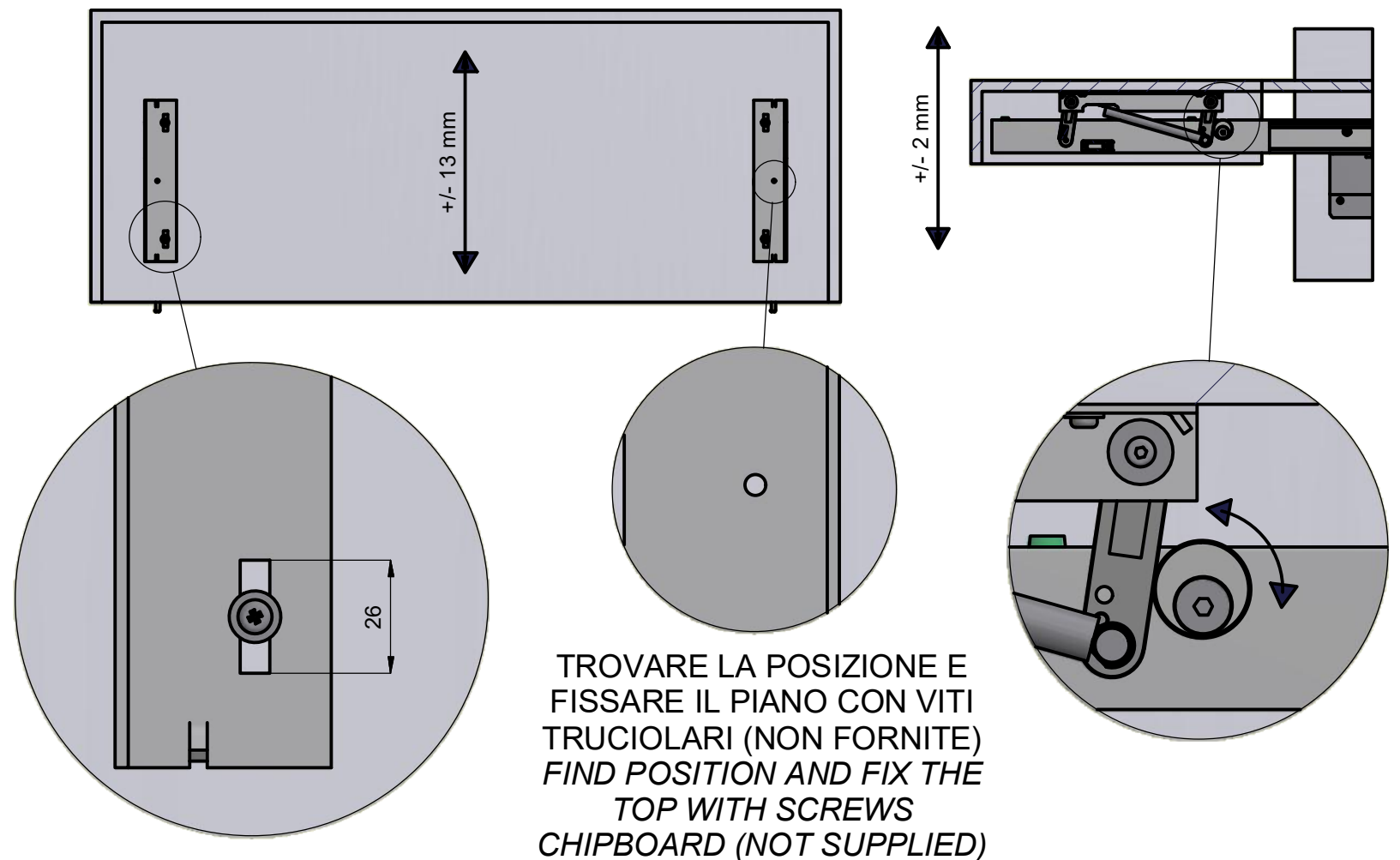

SEQUENZA DI FUNZIONAMENTO FUNCTIONING STEPS

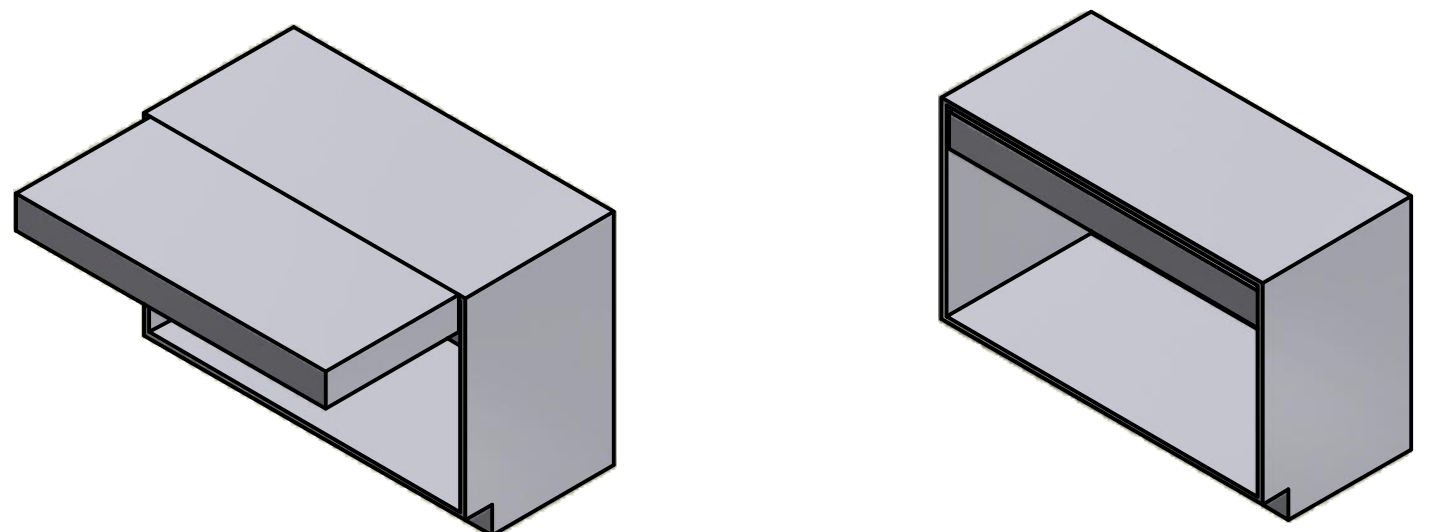

POSIZIONE FORI HOLES POSITION

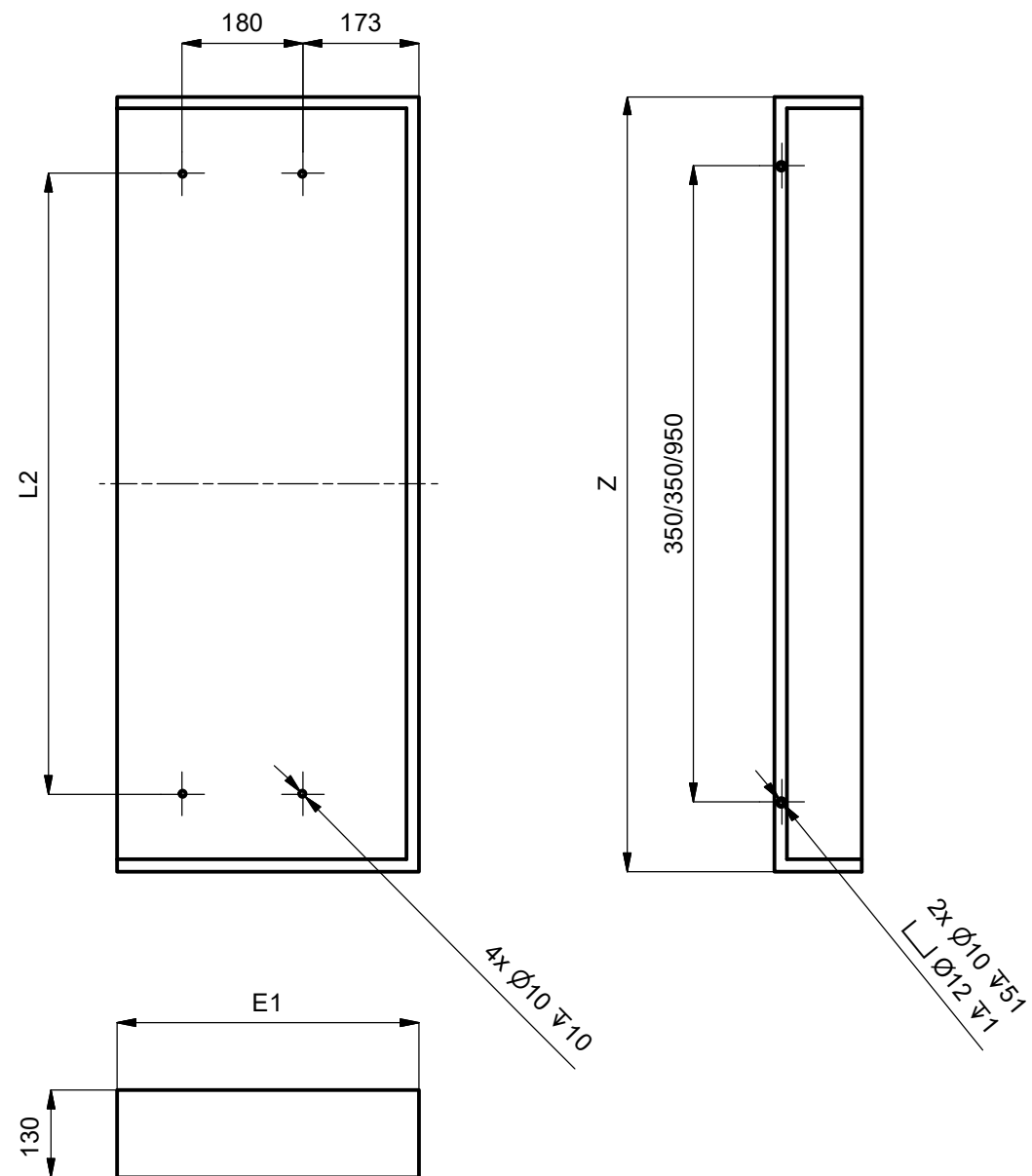
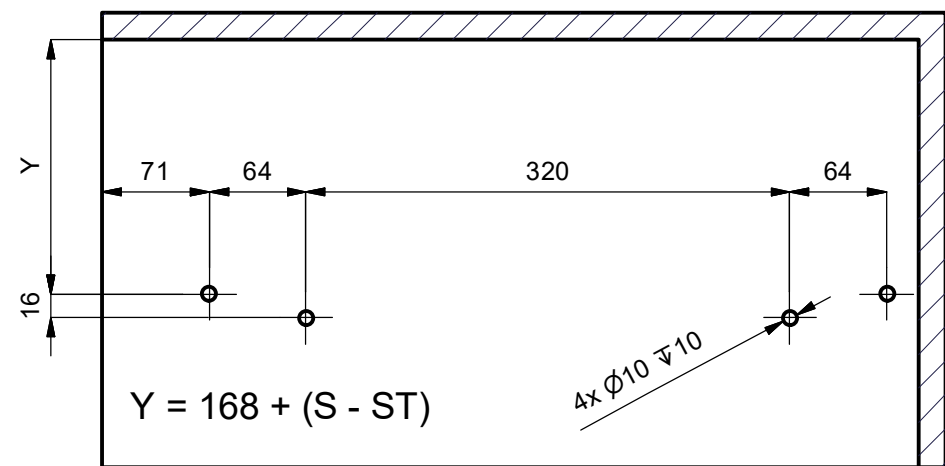

DIMENSIONI GENERALI GENERAL SIZES

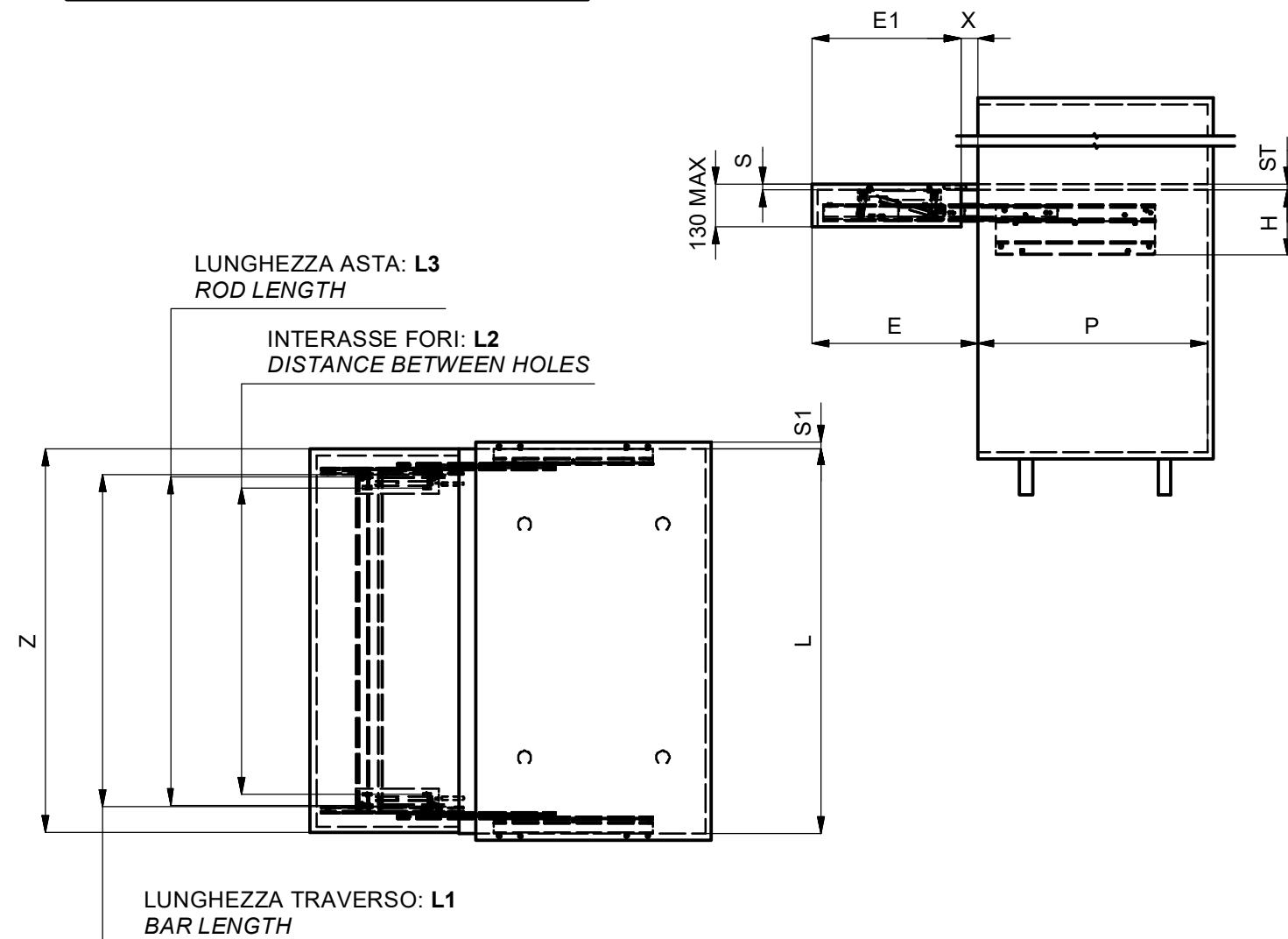

DIMENSIONE - DIMENSION	SIMBOLO - SYMBOL	mm
ALTEZZA - HIGHT	H	MIN: 220
PROFONDITA' - DEPTH	P	MIN: 540
LARGHEZZA - WIDTH	L	MIN: 564 MAX: 1164
SPESSORE PIANO - TOP THICKNESS	S	18
SPESSORE SPALLE - SIDE THICKNESS	S1	18
SPESSORE TOP - COUNTERTOP THICKNESS	ST	MIN: 15 MAX: 35
LARGHEZZA PIANI - TOP WIDTH	Z	L - 5
SPORGENZA - PROTRUSION	X	-
APERTURA PIANI - TOP OPENING	E	500
LUNGHEZZA PIANO - TOP LENGTH	E1	E-X

MODELLO - MODEL	MODULO - MODULE	L1 (mm)	L2 (mm)	L3 +/- 0.20 (mm)
78.1700.25 F	600	401	326.5	391
78.1710.25 F	900	701	626.5	691
78.1720.25 F	1200	1001	926.5	991
78.OPLA FOLDING CUSTOM	CUSTOM	L-162	L-236.5	L-172

MONTAGGIO DEL MECCANISMO

MOUNTING OF THE MECHANISM

