

LUNCH+39

ISTRUZIONI DI MONTAGGIO ASSEMBLY INSTRUCTIONS

MODELLO
MODEL:

411/39.1100.25

CONTENUTO DELLA CONFEZIONE INCLUDED IN THE PACKAGING

- GUIDE - SLIDES

SACCHETTO ACCESSORI - ACCESSORIES

- A. Vite TPS M6x60 - M6x60 FHCS screw (x 4)
- B. Vite TCCE M6x12 - M6x12 SHCS screw (x 8)
- C. Bussola M6 - M6 bush (x 12)
- D. Perno - Pin (x 2)
- E. Chiave esa. da 5 - n° 5 Allen key (x 1)
- F. Chiave esa. da 4 - n° 4 Allen key (x 1)

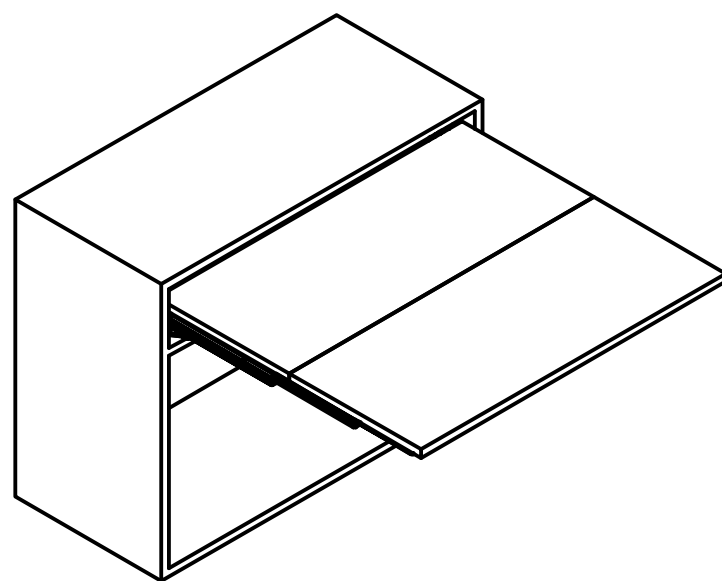

DIMENSIONI GENERALI - GENERAL SIZES

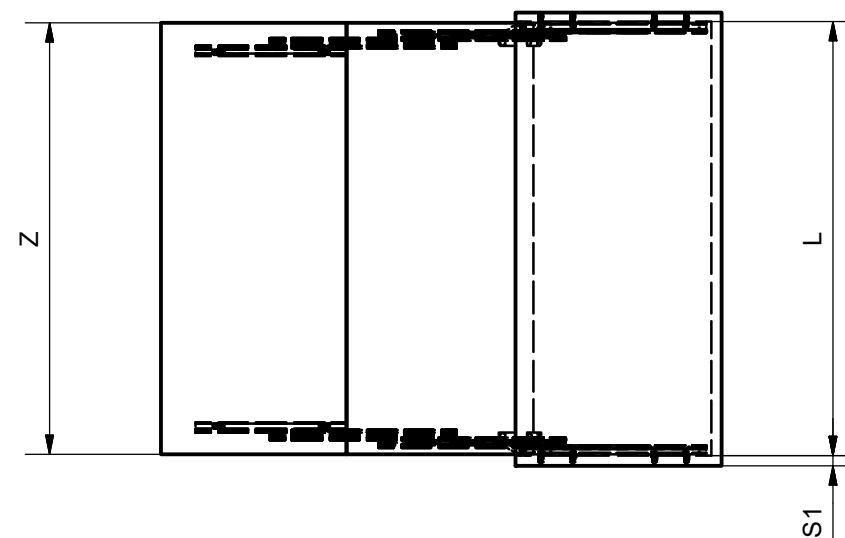
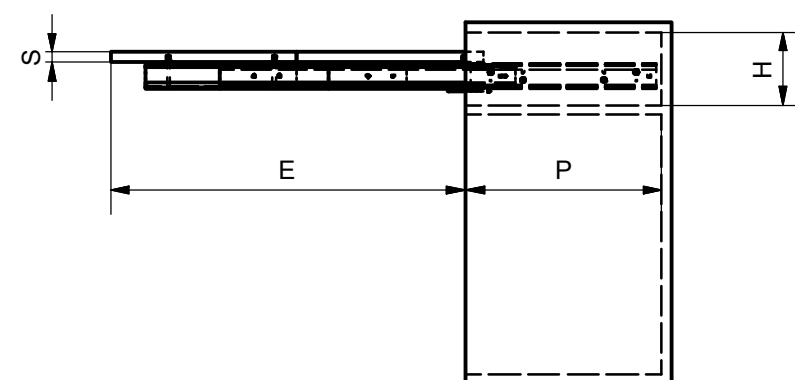

DIMENSIONE - DIMENSION	SIMBOLO - SYMBOL	mm
ALTEZZA - HEIGHT	H	MIN: 120
PROFONDITA' - DEPTH	P	MIN: 390
LARGHEZZA - WIDTH	L	MAX: 1300
SPESSORE SPALLA - SIDE THICKNESS	S1	15-20
SPESSORE PIANO - TOP THICKNESS	S	MIN: 16
LARGHEZZA PIANO - TOP WIDTH	Z	L-5
APERTURA PIANO - OPENING TOP	E	MAX: 790

POSIZIONE FORI - POSITION HOLES

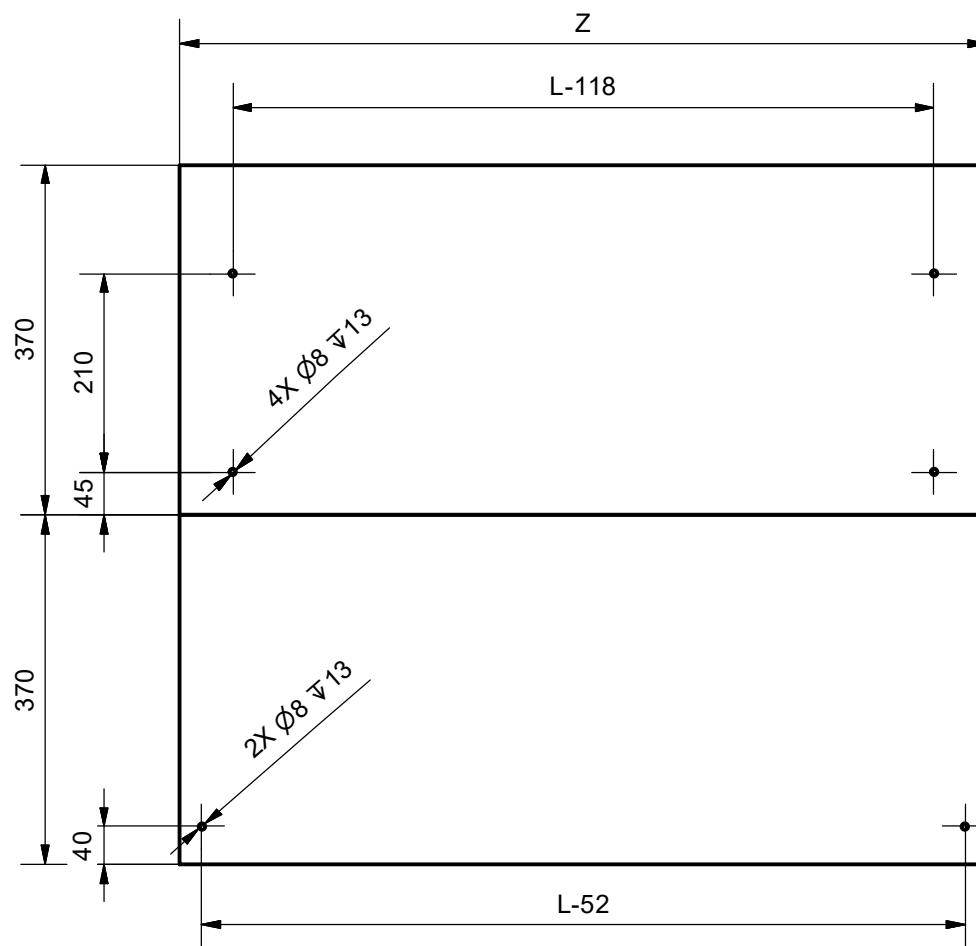
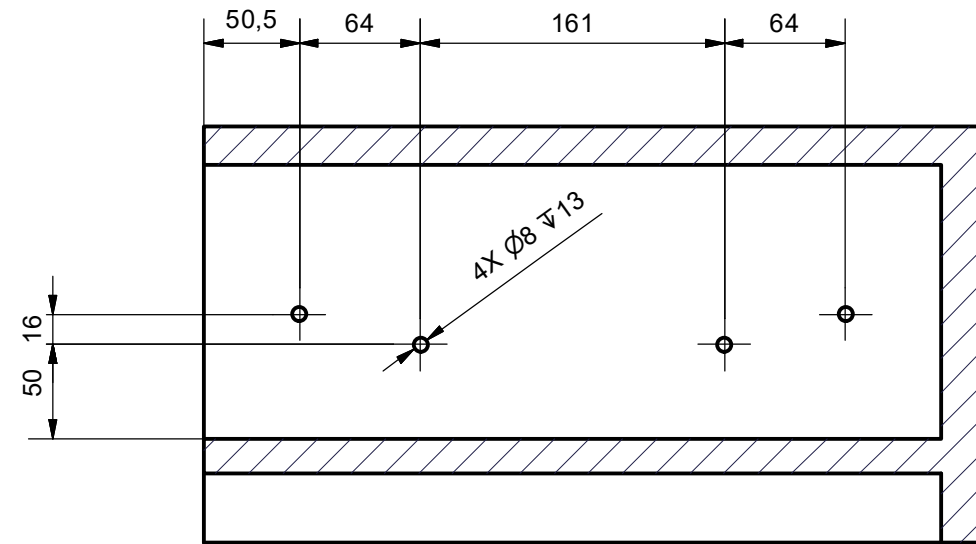

VISTA DAL BASSO - BOTTOM VIEW

MONTAGGIO DEL MECCANISMO - MOUNTING OF THE MECHANISM

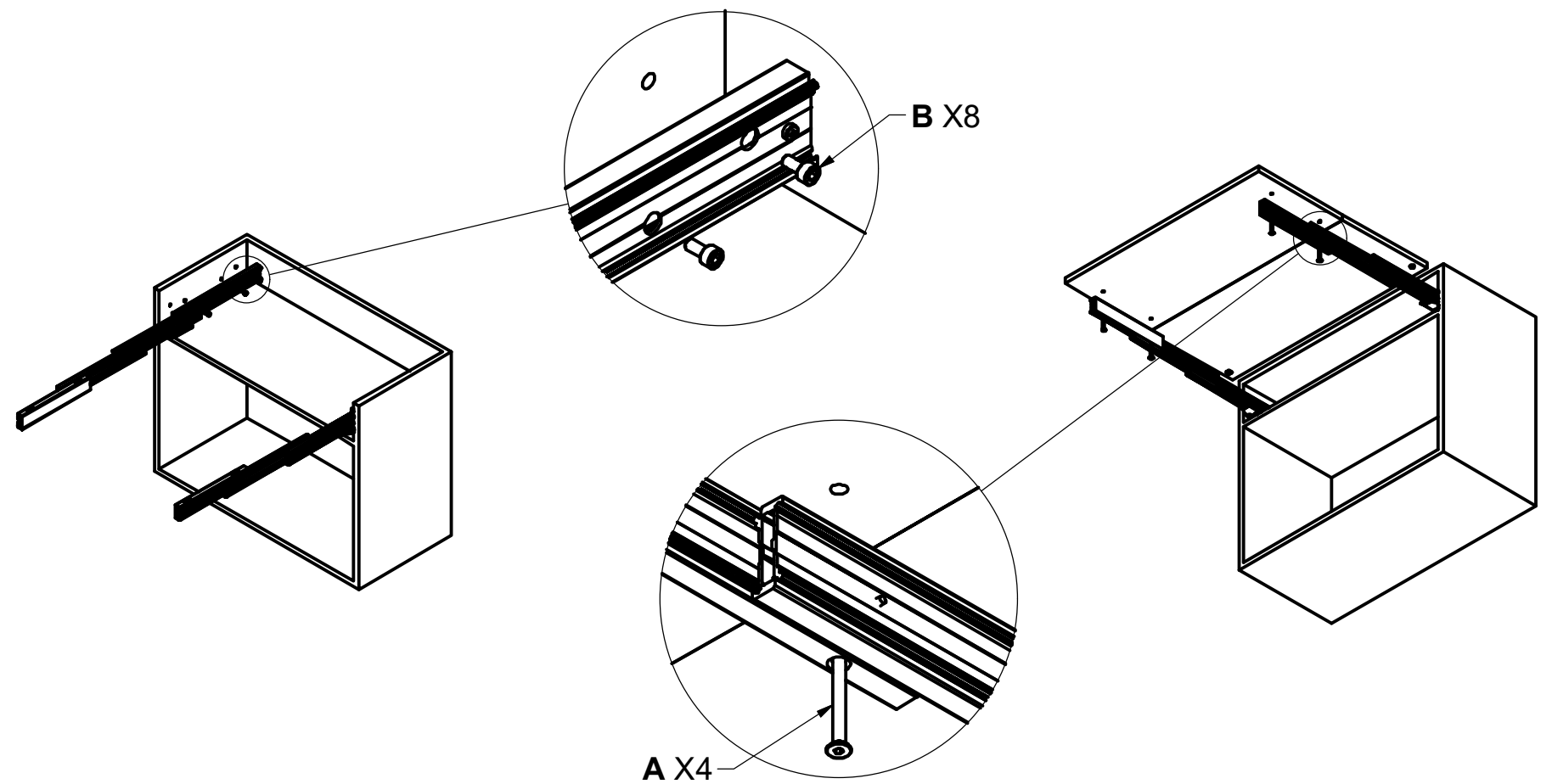

SEQUENZA DI FUNZIONAMENTO - FUNCTIONING STEPS

