

- GB** Installation Guide
- D** Einbauanleitung
- F** Guide d'installation
- I** Guida all'installazione
- E** Guía de instalación
- PL** Instrukcja montażu

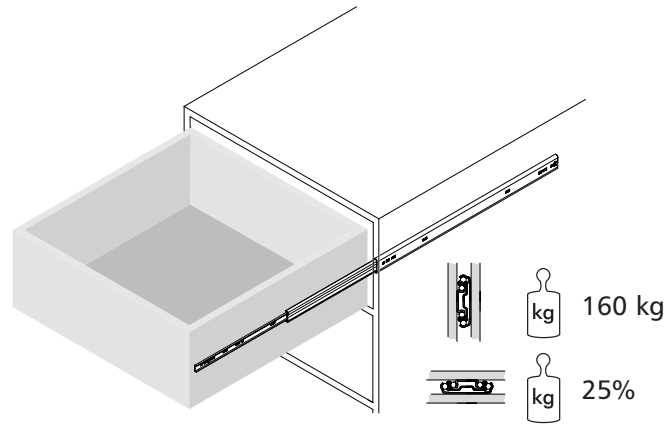

7957

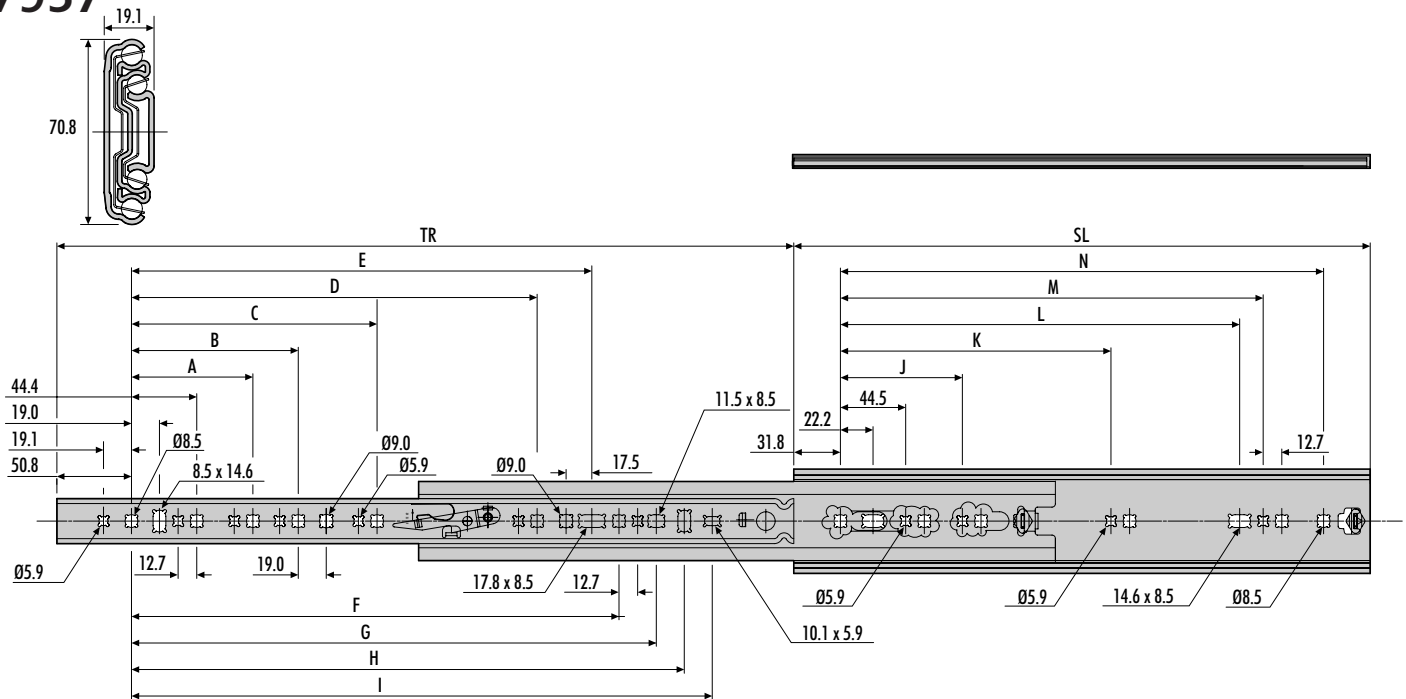

7957	mm															
	SL	TR	A	B	C	D	E	F	G	H	I	J	K	L	M	N
DZ7957-0012-2	304.8	304.8	-	-	-	-	-	-	-	179.4	198.5	-	-	184.2	200.2	241.3
DZ7957-0014-2	355.6	355.6	-	-	-	-	-	-	-	230.2	249.3	-	-	235.0	251.0	292.1
DZ7957-0016-2	406.4	406.4	108.0	-	-	-	-	236.6	262.0	281.0	300.1	-	-	285.8	301.8	342.9
DZ7957-0018-2	457.2	457.2	108.0	-	-	-	-	287.4	312.8	331.8	350.9	-	-	336.6	352.6	393.7
DZ7957-0020-2	508.0	508.0	108.0	171.5	-	-	-	338.2	363.6	382.6	401.7	-	-	387.4	403.4	444.5
DZ7957-0022-2	558.8	558.8	108.0	171.5	-	-	328.7	389.0	414.4	433.4	452.5	-	-	438.2	454.2	495.3
DZ7957-0024-2	609.6	609.6	108.0	171.5	-	-	379.5	439.8	465.2	484.2	503.3	-	-	489.0	505.0	546.1
DZ7957-0026-2	660.4	660.4	108.0	171.5	-	-	430.3	490.6	516.0	535.0	554.1	-	-	539.8	555.8	596.9
DZ7957-0028-2	711.2	711.2	108.0	171.5	-	-	481.1	541.4	566.8	585.8	604.9	-	-	590.6	606.6	647.7
DZ7957-0030-2	762.0	762.0	108.0	171.5	-	-	531.9	592.2	617.6	636.6	655.7	203.2	469.9	641.4	657.4	698.5
DZ7957-0032-2	812.8	812.8	108.0	171.5	-	-	582.7	643.0	688.4	687.4	706.5	203.2	520.7	692.2	708.2	749.3
DZ7957-0034-2	863.6	863.6	108.0	171.5	349.3	-	633.5	693.8	719.2	738.2	757.3	203.2	571.5	743.0	759.0	800.1
DZ7957-0036-2	914.4	914.4	108.0	171.5	349.3	501.7	684.3	744.6	770.0	789.0	808.1	203.2	622.3	793.8	809.8	850.9

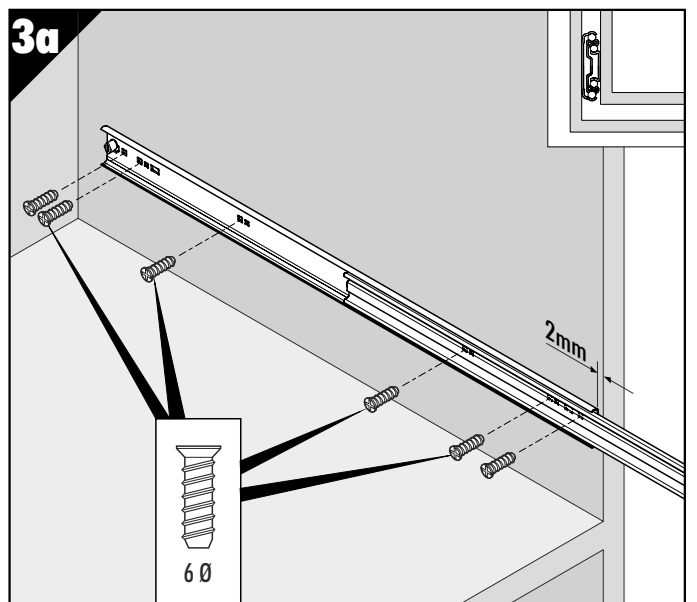
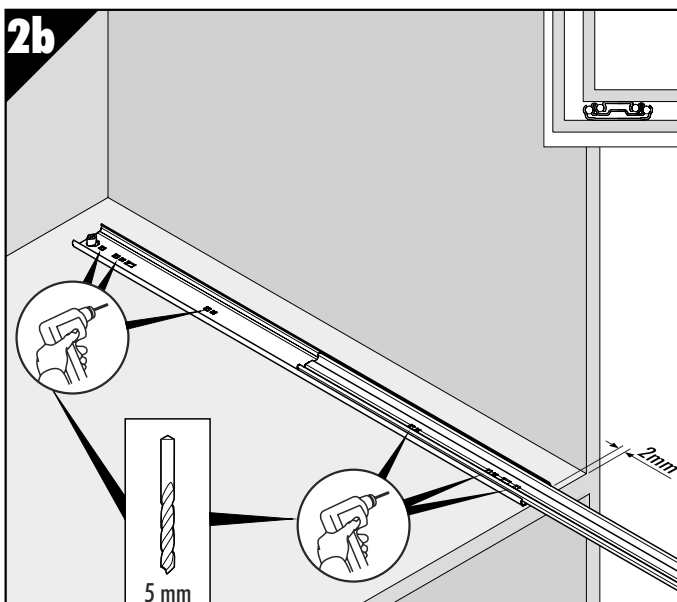
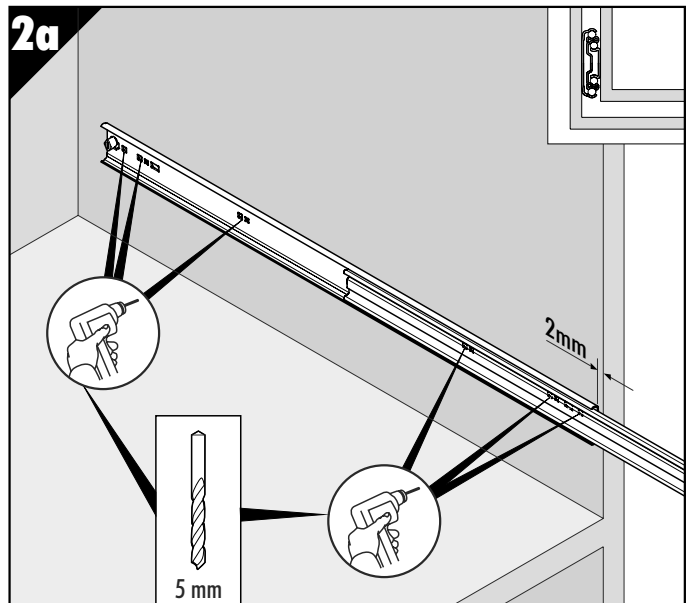
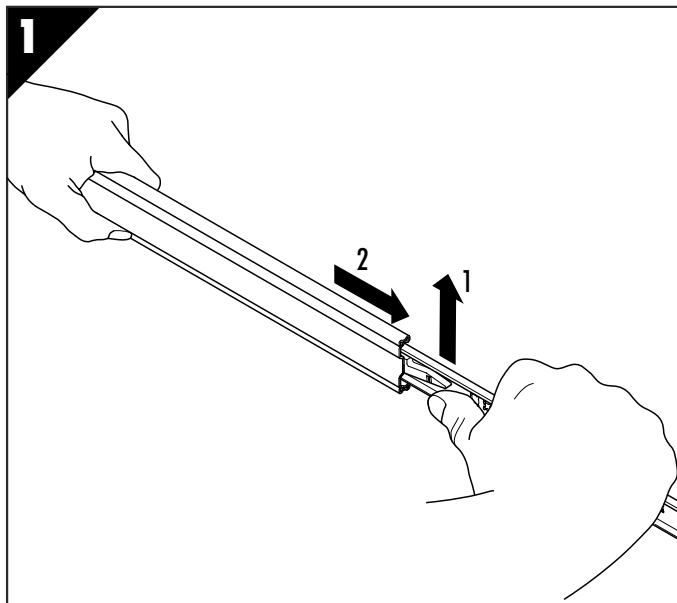
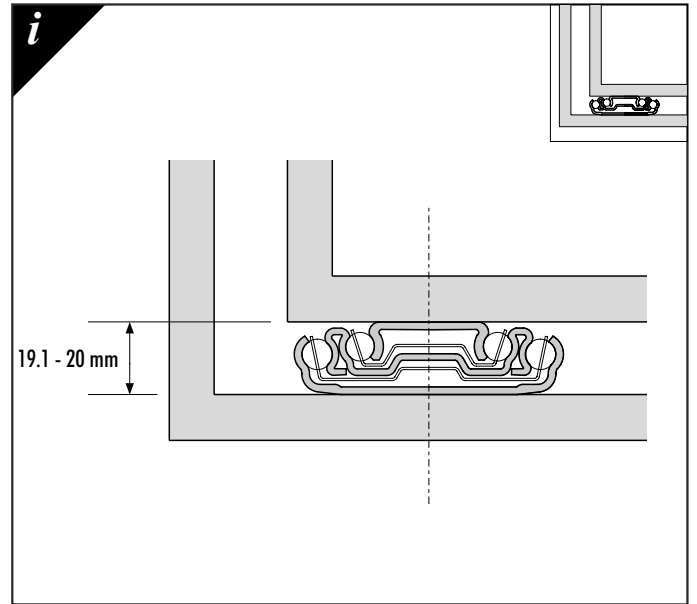
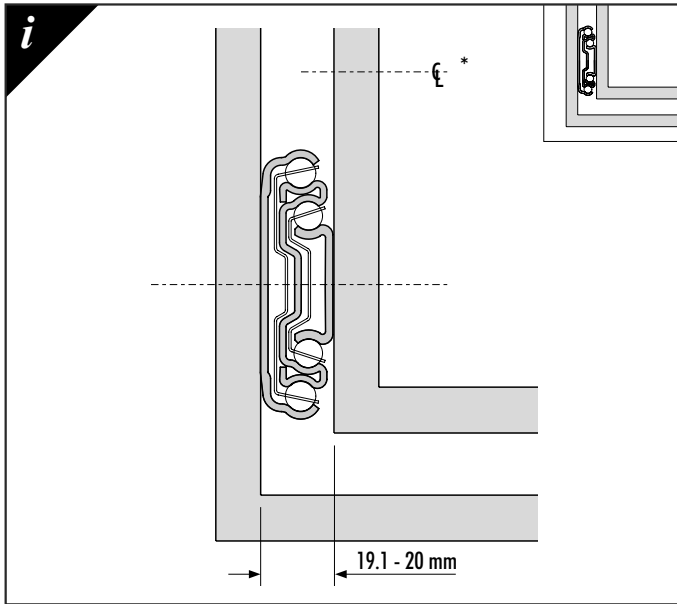

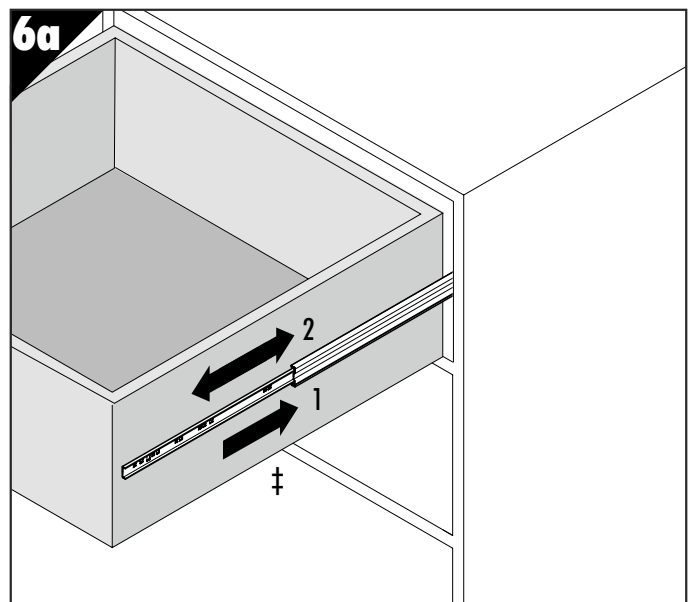
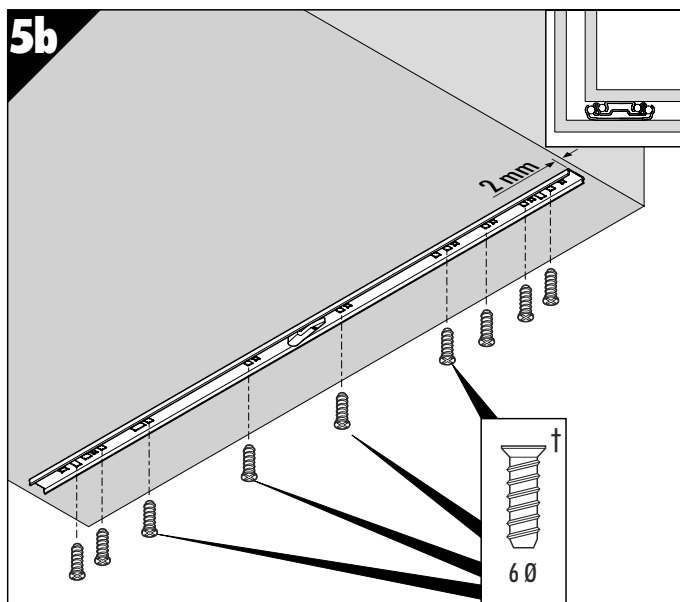
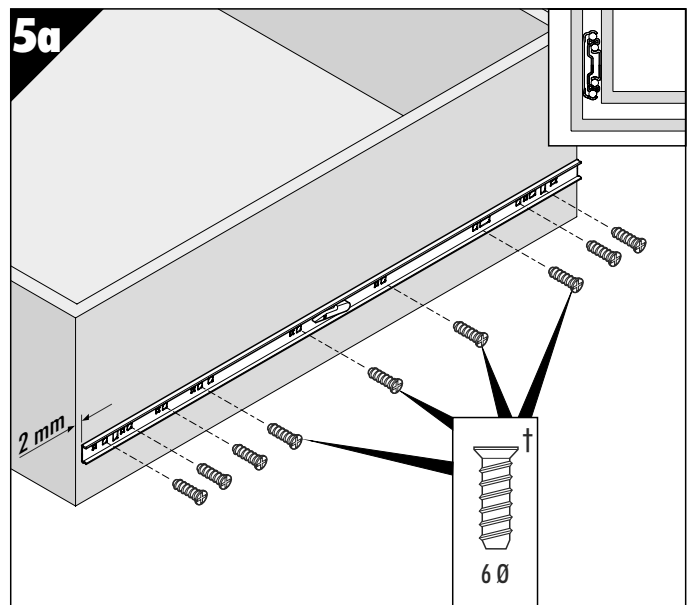
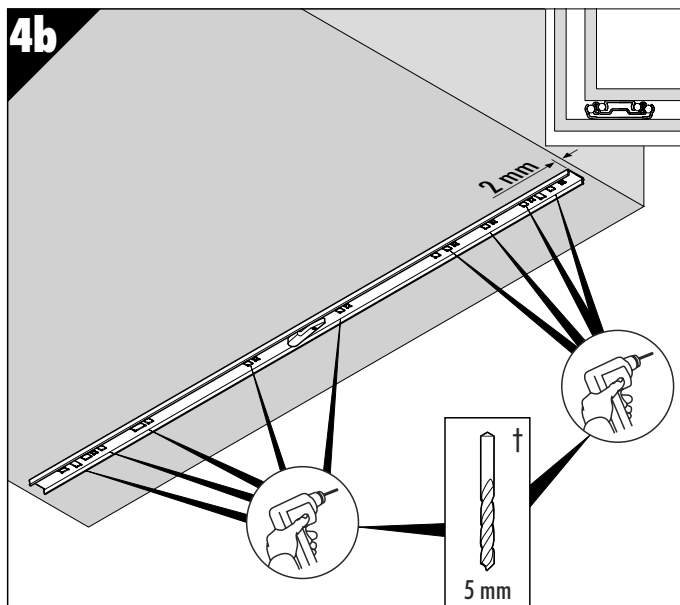
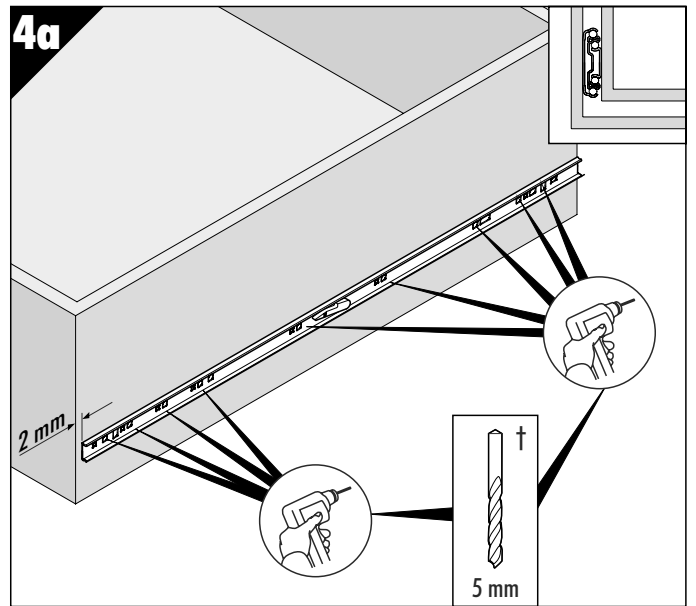
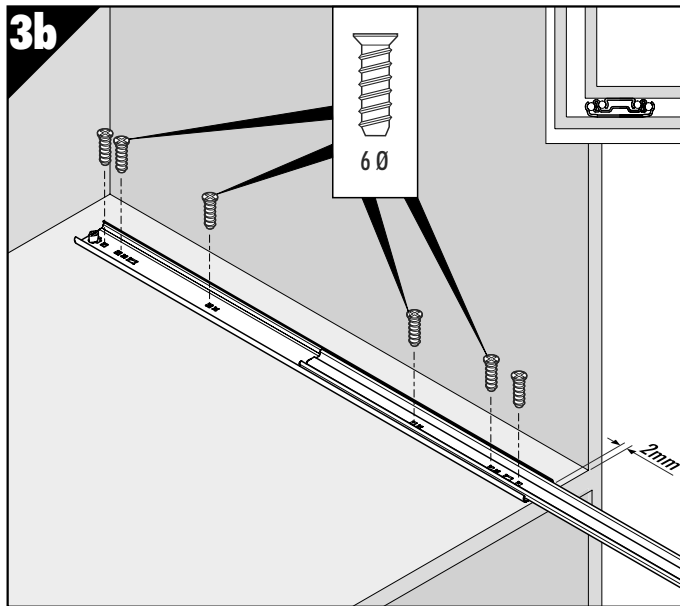

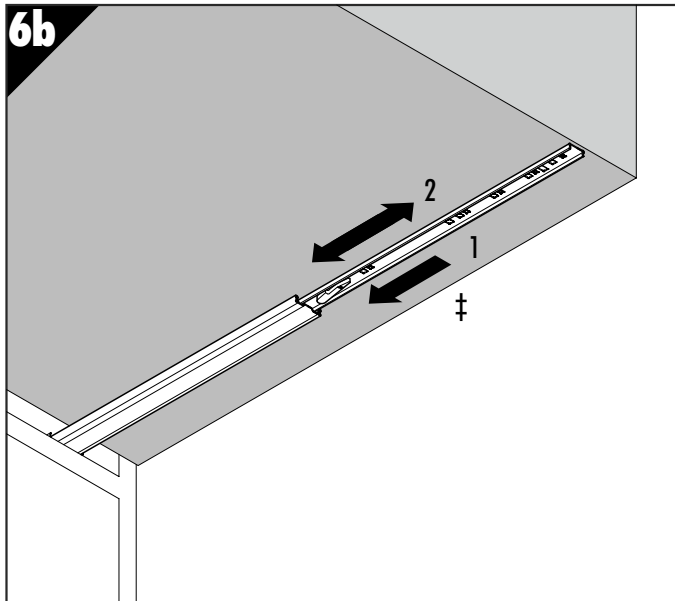

- GB** * Mount slide below drawer centre line.
† All fixings positions must be used to achieve maximum load rating.
‡ Hold ball bearing retainer in forward position during installation of drawer.
- D** * Einbau der Schiene unterhalb der Schubladen-Mittellinie.
† Es sind alle Befestigungspositionen zu verwenden, damit der maximale Lastwert erzielt wird.
‡ Hält den Kugelkäfig während der Schubladenbefestigung vorne.
- F** * Monter la glissière sur l'axe du tiroir de celui-ci.
† Tous les points de fixation doivent être utilisés pour obtenir la charge maximale.
‡ Maintenir la cage à billes en position avant pendant l'installation du tiroir.
- I** * Montare la guida sulla linea di mezzeria del cassetto.
† Per ottenere il massimo carico nominale, devono essere usate tutte le posizioni di fissaggio.
‡ Mantenere la gabbietta portasfera in posizione avanzato durante il montaggio del cassetto.
- E** * Monte la guía por debajo de la línea central.
† Todas las posiciones de fijación deben ser usadas para se conseguir la capacidad máxima de carga.
‡ Mantenga el cojinete de bolas en la posición de frente durante la instalación del cajón.
- PL** * Prowadnice należy montować poniżej osi szuflady.
† Dla uzyskania maksymalnej nośności należy wykorzystać wszystkie punkty montażowe.
‡ Podczas instalacji szuflady koszyk z kulkami powinien znajdować się w pozycji frontowej.

Accuride International Ltd.

Liliput Road, Brackmills Industrial Estate, Northampton
NN4 7AS, United Kingdom.
Tel: +44 (0) 1604 761111 Fax: +44 (0) 1604 767190
E-mail: saleseurope@accuride.com
www.accuride-europe.com

GB If you require further assistance, please contact your distribution agent or supplier.
Accuride reserve the right to alter specifications without notice.

D Bei Fragen wenden Sie sich bitte an Ihren Vertriebspartner.
Technische Änderungen vorbehalten.

F Pour de plus amples renseignements, veuillez contacter votre distributeur.
Accuride se réserve le droit de modifier les spécifications sans préavis.

Accuride International GmbH

Werner-von-Siemens-Str. 16-18,
65582 Diez/Lahn
Tel: + 49 (0) 6432 608-0
Fax: + 49 (0) 6432 608-320

I Qualora necessitate di ulteriore assistenza, contattate il fornitore o il vostro agente.
Accuride si riserva il diritto di apportare modifiche senza ulteriore comunicazione.

E Si necesita más ayuda, póngase en contacto con su agente de distribución o proveedor.
Accuride se reserva el derecho de alterar las especificaciones sin aviso previo.

PL W przypadku dodatkowych pytań proszę zwrócić się do dostawcy.
Accuride zastrzega sobie prawo do wprowadzania zmian technicznych bez wcześniejszej informacji.