

**9** Offer door to frame. Mark and fix screws in two positions. Check door alignment before marking and fixing the remaining screws.

**IMPORTANT:**  
When fitting components to the door ensure screws do not protrude through inset panels

For reliable and safe performance of the unit, all door fixing screws must be used.

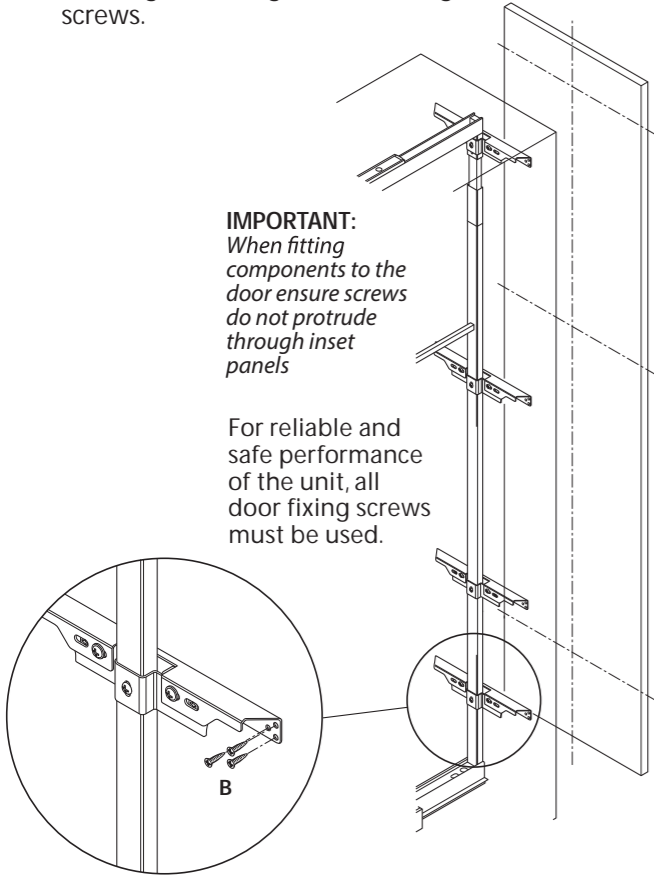

**10** Adjust vertical door alignment with the 3 door bracket screws.

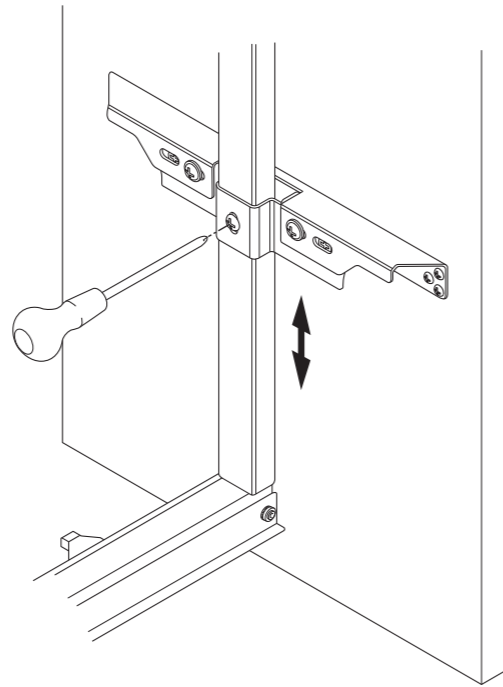

**11** Adjust the vertical alignment of the door with the Allen screw located under the bottom runner.

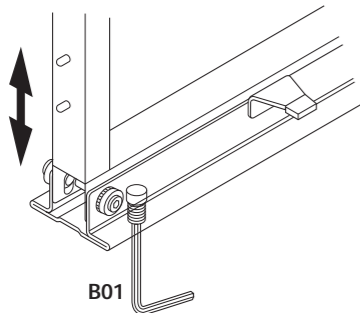

'Fine' adjustment of the vertical alignment of the door can be achieved by compressing the stop cover and sliding towards the front or rear.

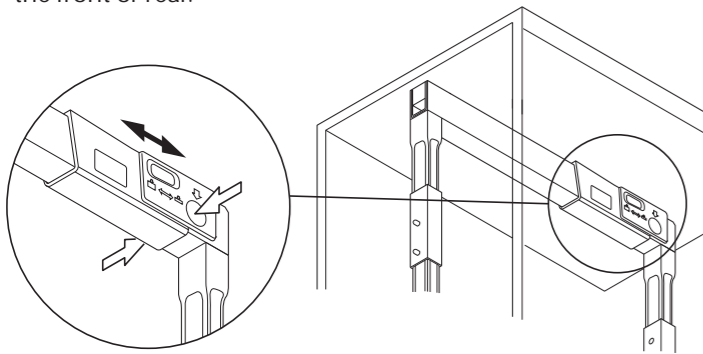

**12** Adjust the horizontal and lateral door alignment with screws on the door brackets.

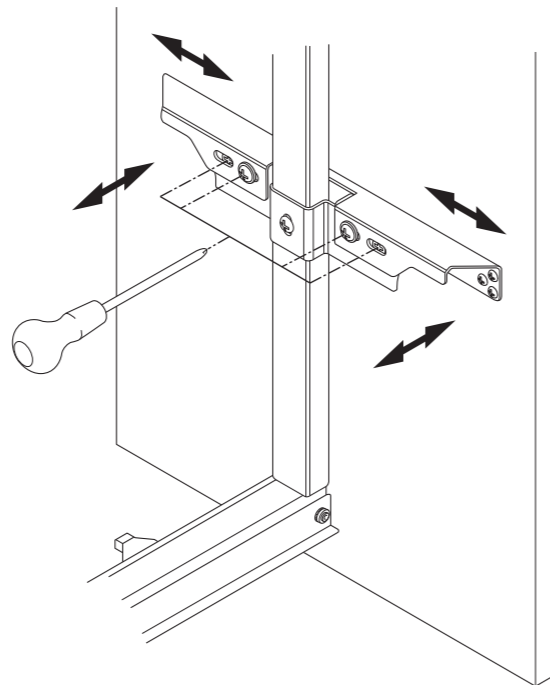

## LARDER PLUS - 300mm (IP2L31)

### Assembly and fitting instructions

ono **storplus**™



**IMPORTANT** - The unit has a maximum loading limit of 100kg. Load should be evenly distributed across all trays with maximum load capacity for each tray not exceeding 16kg.  
No lubricant should be used on the runners.  
All fixings supplied **MUST** be used in the locations specified during installation.

Unit must be securely fixed to the wall using the fixing bracket.

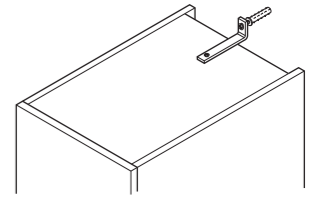

**PLEASE NOTE** - Failure to use all supplied fittings according to instructions may void warranty. Handles must be mounted on the door in a central position in order to guarantee operation.

**WARNING!** LARDER UNITS CAN BE HEAVY AND DANGEROUS. FAILURE TO CORRECTLY FOLLOW THESE INSTALLATION INSTRUCTIONS COULD LEAD TO PERSONAL INJURY.

Parts **A** x8 M6 washer

**B** x36 3.5 x 16mm screw

**C** x8 M6 x 12mm screw

**D** x8 M6 x 12mm countersunk screw

**E** x4 M5 x 12mm screw

**F** M6 x 60mm bolt

**G** M6 wide washer

**H** M6 nut

Tools required

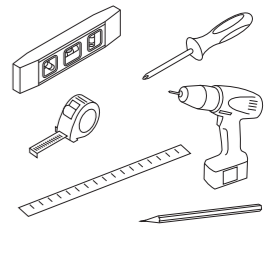

**J** Top runner x1

**K** Stop spring x1

**L** Soft close piston x1

**M** Rubber stop x1

**T** Bottom runner x1

**U** Frame mounting bracket x4

**V** Door mounting bracket x4

**W** Tray mounting clip x12

**Y** Runner fitting template x1

**P** Top frame x1

**Q** Top basket collar x2

**N** Stop cover x1

**R** Ring x2

**S** Bottom frame x1

**A01** x1 Allen key 2.5mm

**B01** x1 Allen key 4mm **C01** x8 M5 Grub screw (pre installed in frame)

**X** Tray x6

x1 Wall fixing bracket kit (must be used for cabinets not already secured to wall)



Please ensure that all the above fittings are present before installation begins.

**1** Align bottom template on centre line of cabinet base and secure with masking tape. Mark 7 screw fixing positions. Remove template and screw bottom runner to cabinet base.

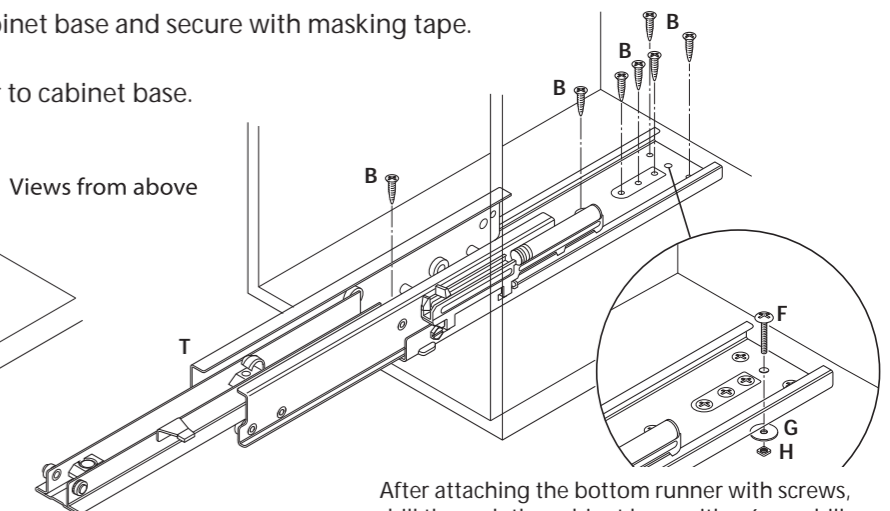
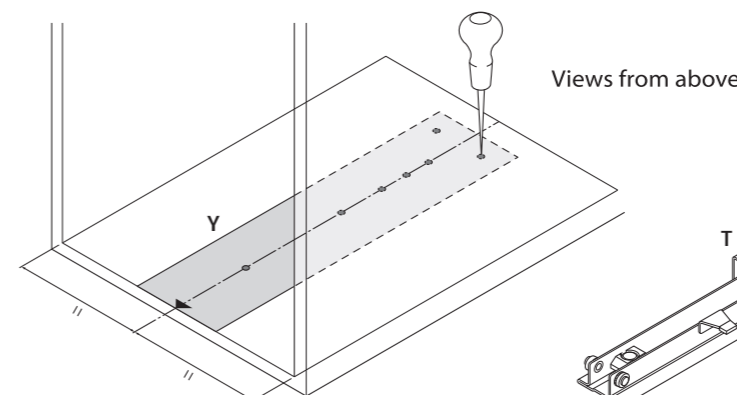

After attaching the bottom runner with screws, drill through the cabinet base with a 6mm drill bit via the rear central hole on the runner. Use parts F, G and H to secure the runner as shown.

**!** Now refer back to instruction No. 7 and check the distance is still 61mm front and back. If not, release grub screws C01 and make the necessary adjustments.

**2** Align top template on centre line of cabinet top and secure using masking tape. Mark 5 screw fixing positions. Remove template and screw top runner to cabinet top.

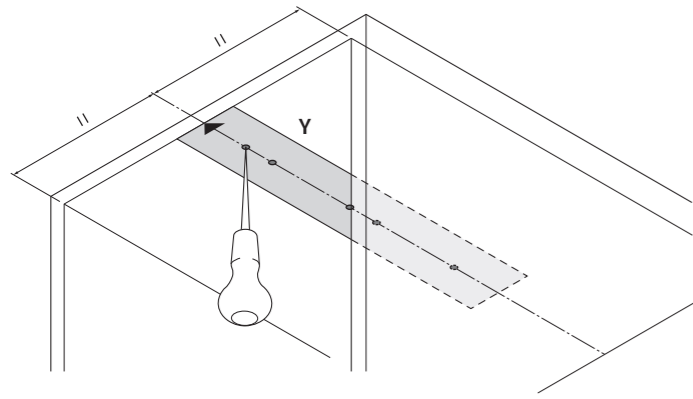

Views from below

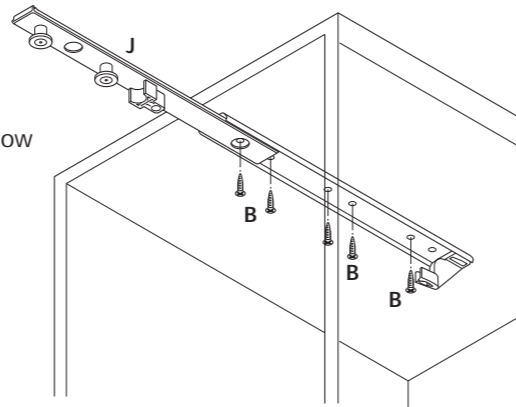

**5** Insert top runner into top of frame. Use grub screws on forward and rear frame uprights to adjust height to 61mm.

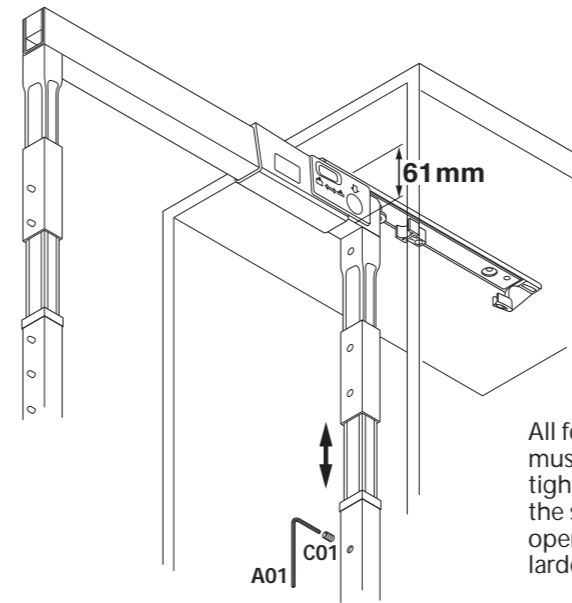

Views from below

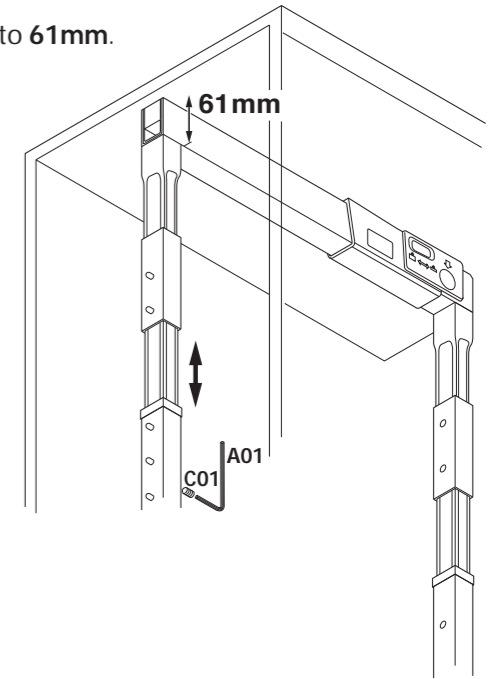

All four grub screws must be securely tightened to ensure the safe and effective operation of the larder unit.

**3** Assemble the components in the top frame.

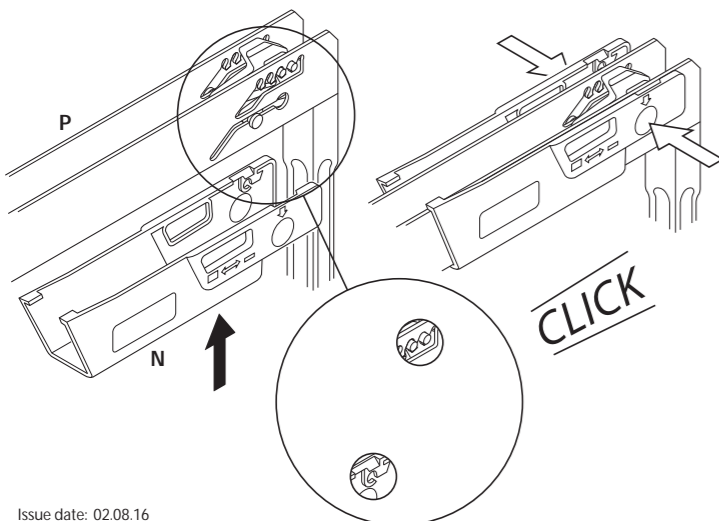
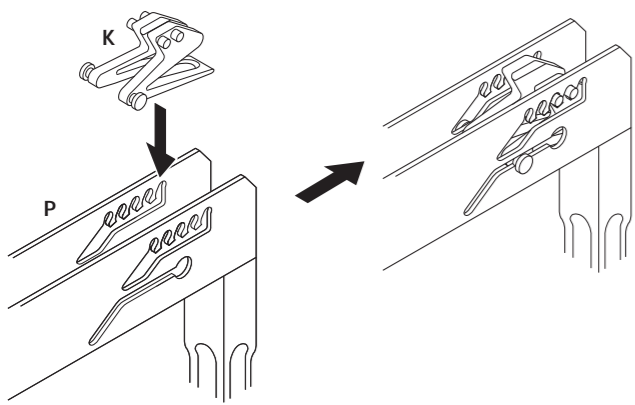
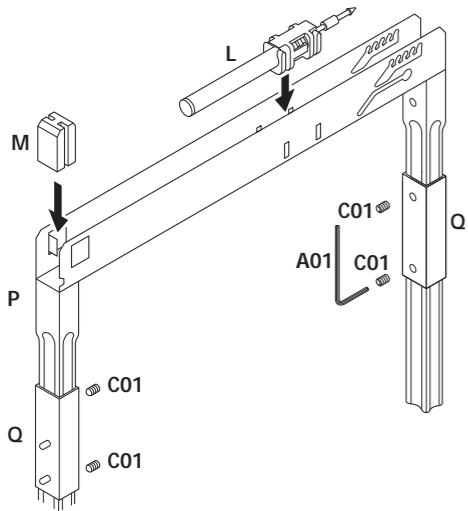

**4** Insert the top into the bottom frame, and then attach this assembly to the bottom runner.

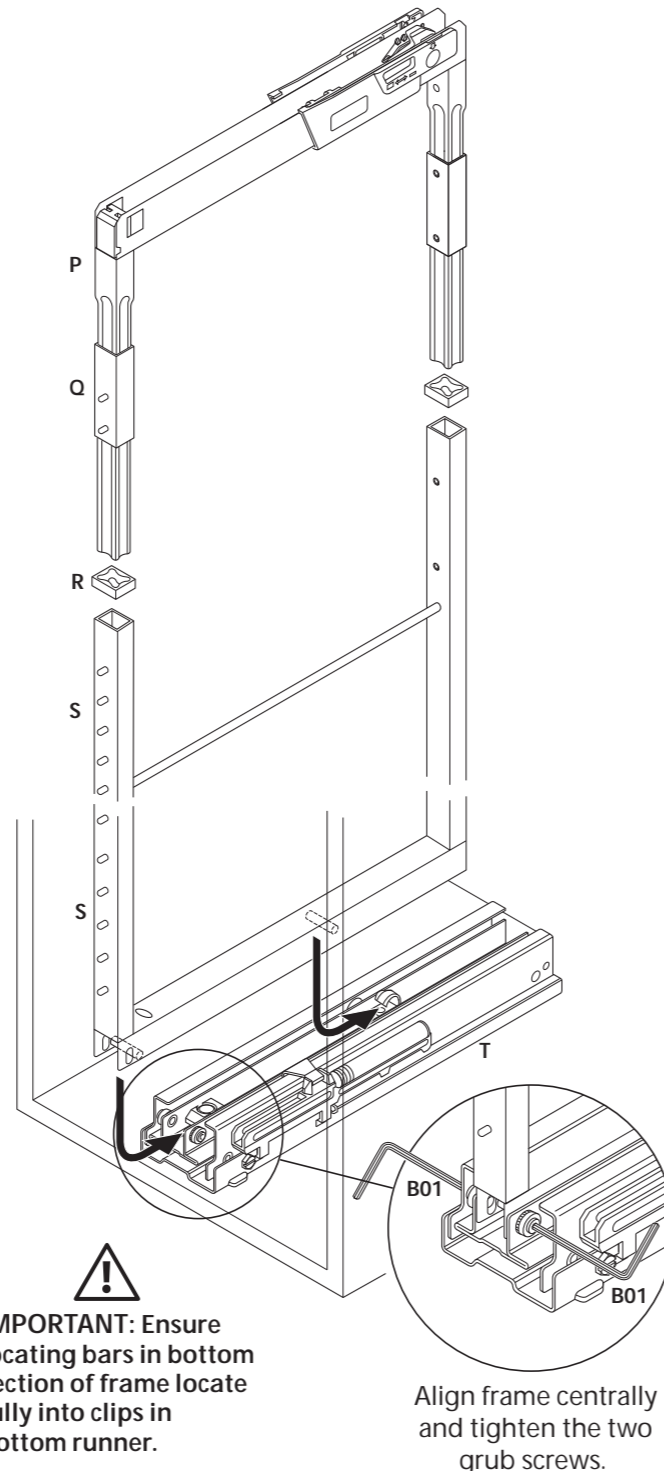

**IMPORTANT:** Ensure locating bars in bottom section of frame locate fully into clips in bottom runner.

Align frame centrally and tighten the two grub screws.

**6** Fit adjustment screws to frame brackets and attach frame brackets to frame upright.

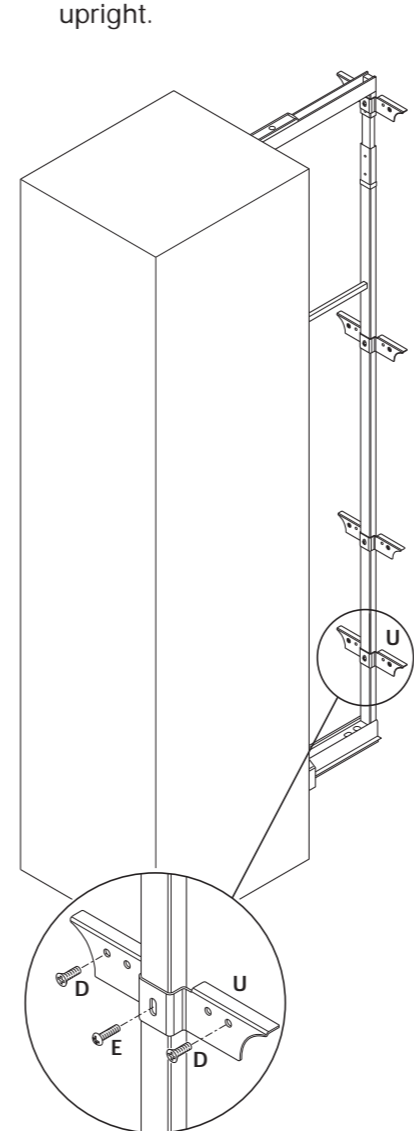

Issue date: 02.08.16

**7** Fit door brackets to frame brackets.

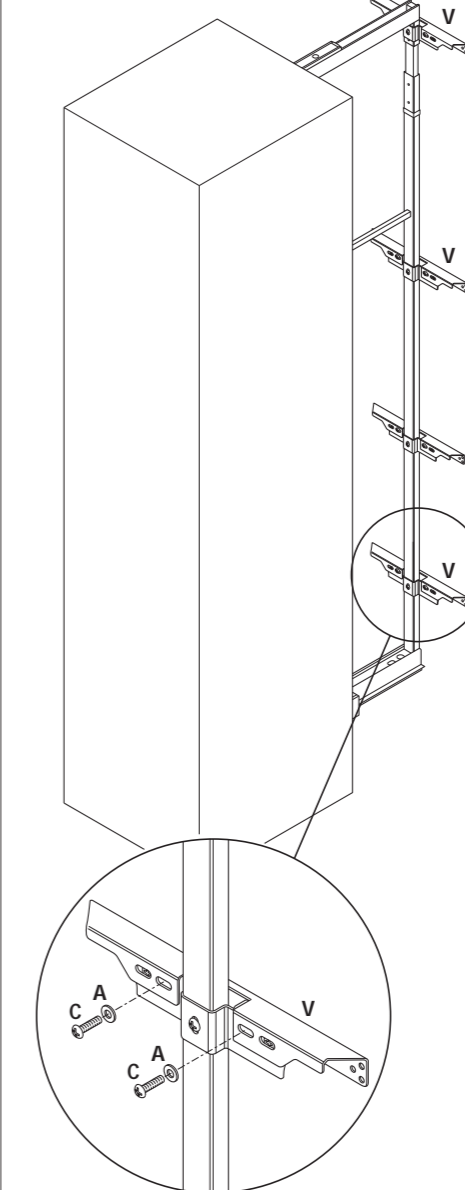

**8** Attach the tray mounting clips to the frame and insert the trays.

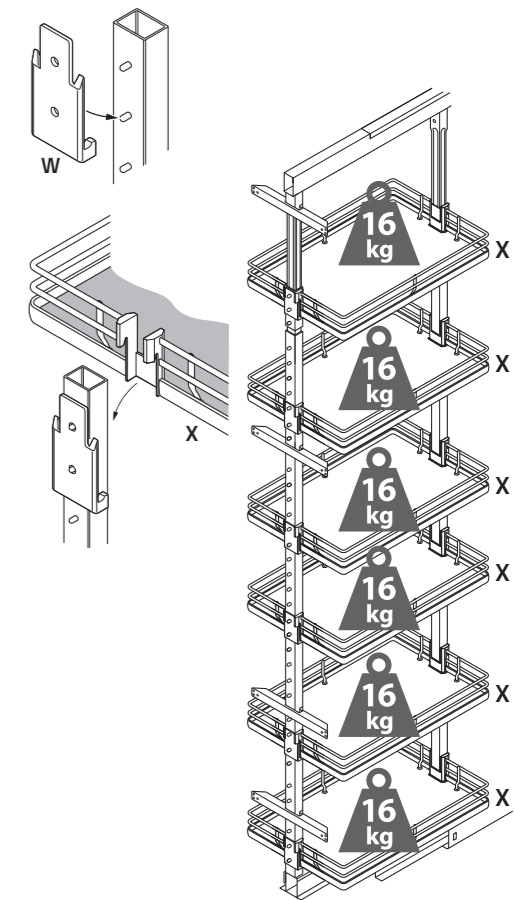

**IMPORTANT -** The unit has a maximum loading limit of 100kg. Load should be evenly distributed across all trays with maximum load capacity for each tray not exceeding 16kg.